

[www.osaka.com.tr](http://www.osaka.com.tr)

OSAKA®

2024

Professional

Air Tools Catalog





<i>Impact Wrenches</i>	<b>4-11</b>
<i>Ratchet Wrenches / Digital Torque Arms</i>	<b>13-14</b>
<i>Drills</i>	<b>15-16</b>
<i>Screwdrivers</i>	<b>17-20</b>
<i>Tapping Machines / Telescopic Reaction Arms</i>	<b>21-23</b>
<i>Nailers / Staplers</i>	<b>24-26</b>
<i>Cutting Tools / Filing Machines / Steel Strapping Machine</i>	<b>26-27</b>
<i>Die Grinders</i>	<b>28-30</b>
<i>Pipe Grinders / Engraving Pen / Micro Die Grinder</i>	<b>31-32</b>
<i>Grinders</i>	<b>33-34</b>
<i>Polishers</i>	<b>35</b>
<i>Sanders</i>	<b>36-38</b>
<i>Saws / Palm Hammer / Spot Drill</i>	<b>39</b>
<i>Riveting Tools</i>	<b>40-42</b>
<i>Chipping Hammers / Needle Scalers</i>	<b>44-46</b>
<i>Mixers / Air Dent Puller / Vacuum</i>	<b>46</b>
<i>Caulking Guns / Grease Guns</i>	<b>47</b>
<i>FRL Units</i>	<b>48-49</b>
<i>Osaka Hoses</i>	<b>52-55</b>
<i>Tecna Balancers</i>	<b>58-60</b>
<i>Osaka Impact Sockets</i>	<b>64-76</b>
<i>Lüdecke Quick Couplings</i>	<b>80-82</b>
<i>Osaka Accessories</i>	<b>86-95</b>
<i>Osafix Rivets</i>	<b>98-102</b>
<i>Heller Drill Bits</i>	<b>104-105</b>
<i>Service Points</i>	<b>106</b>
<i>Technical Informations</i>	<b>107-109</b>
<i>Procut Index</i>	<b>110-112</b>
<i>Bank Informations</i>	<b>112</b>



**OSAKA®** [www.osaka.com.tr](http://www.osaka.com.tr)

Pneumatic Hand Tools



### OPT 375 3/8" IMPACT WRENCH



SINGLE HAMMER	
Length	139 mm
Bolt Diameter	12 mm
Square Drive	3/8"
Max. Torque	102 Nm
Free Speed	10.000 Rpm
Air Consumption	113 l/min
Air Inlet	1/4"
Hose Diameter	8.00 mm
Working Pressure	90 psi (6.2 atü)
Weight	0.95 kg
Box Quantity	20 pcs

### OPT 371 3/8" IMPACT WRENCH



SINGLE HAMMER	
Length	112 mm
Bolt Diameter	12 mm
Square Drive	3/8"
Max. Torque	102 Nm
Free Speed	9.000 Rpm
Air Consumption	100 l/min
Air Inlet	1/4"
Hose Diameter	8.00 mm
Working Pressure	6.3-8 atü
Weight	1.1 kg
Box Quantity	20 pcs

### OPT 517 1/2" IMPACT WRENCH



TWIN HAMMER	
Length	185 mm
Bolt Diameter	18 mm
Square Drive	1/2"
Max. Torque	651 Nm
Free Speed	7.000 Rpm
Air Consumption	120 l/min
Air Inlet	1/4"
Hose Diameter	10.00 mm
Working Pressure	90 psi (6.2 atü)
Weight	2.55 kg
Box Quantity	10 pcs

### OPT 517K 1/2" IMPACT WRENCH SET



TWIN HAMMER	
1 pc OPT 517 + 10 pcs Impact Sockets + 1 pc Tool Box + 1 pc 125 mm Extension	
Impact Sockets 1/2"	9-10-11-13-14-17-19-22-24-27 mm
Air Inlet	1/4"
Air Consumption	120 l/min
Working Pressure	90-115 psi (6.2 atü)
Weight	2.55 kg
Box Quantity	6 pcs

### OPT-P 243 3/8" IMPACT WRENCH



TWIN HAMMER	
Length	155 mm
Bolt Diameter	14 mm
Square Drive	3/8"
Max. Torque	298 Nm
Free Speed	10.000 Rpm
Air Consumption	80 l/min
Air Inlet	1/4"
Hose Diameter	10.00 mm
Working Pressure	90 psi (6.2 atü)
Weight	1.50 kg
Box Quantity	10 pcs

### OPC 50138 3/8" IMPACT WRENCH



SINGLE HAMMER	
Length	127 mm
Bolt Diameter	8 mm
Square Drive	3/8"
Max. Torque	70 Nm
Free Speed	12.000 Rpm
Air Consumption	120 l/min
Air Inlet	1/4"
Hose Diameter	8.00 mm
Working Pressure	90 psi (6.2 atü)
Weight	0.73 kg
Box Quantity	20 pcs

### OPT-P 519 1/2" IMPACT WRENCH



TWIN HAMMER	
Length	155 mm
Bolt Diameter	16 mm
Square Drive	1/2"
Max. Torque	850 Nm
Free Speed	7.400 Rpm
Air Consumption	250 l/min
Air Inlet	1/4"
Hose Diameter	10.00 mm
Working Pressure	90 psi (6.2 atü)
Weight	2.50 kg
Box Quantity	6 pcs

### OPT-P 520 1/2" IMPACT WRENCH



TWIN HAMMER	
Length	164 mm
Bolt Diameter	18 mm
Square Drive	1/2"
Max. Torque	1.054 Nm
Free Speed	6.200 Rpm
Air Consumption	300 l/min
Air Inlet	1/4"
Hose Diameter	10.00 mm
Working Pressure	90 psi (6.2 atü)
Weight	2.20 kg
Box Quantity	6 pcs

### OPC 50238C 3/8" IMPACT WRENCH



TWIN HAMMER - COMPOSITE	
Length	165 mm
Bolt Diameter	14 mm
Square Drive	3/8"
Max. Torque	434 Nm
Free Speed	12.000 Rpm
Air Consumption	210 l/min
Air Inlet	1/4"
Hose Diameter	10.00 mm
Working Pressure	6.3-8 atü
Weight	1.20 kg
Box Quantity	10 pcs

### OPT-P 59212 1/2" IMPACT WRENCH



1/2" IMPACT WRENCH BATTERY TYPE	
Bolt Diameter	14 mm
Square Drive	1/2"
Max. Torque	474 Nm
Free Speed	2.300 Rpm
Battery	19.2 V/Li-ion
Charging Time	60 min
Weight	1.90 kg
Standard Acc.	1 pc 19.2 V Akü, Şarj Ünitesi
Box Quantity	6 pcs

### OPT-P 504C STUBBY IMPACT WRENCH



STUBBY IMPACT WRENCH	
Length	90 mm
Bolt Diameter	16 mm
Square Drive	1/2"
Max. Torque	610 Nm
Free Speed	9.000 Rpm
Air Consumption	300 l/min
Air Inlet	1/4"
Hose Diameter	8.00 mm
Working Pressure	90 psi (6.2 atü)
Weight	1.19 kg
Box Quantity	12 pcs

### OPC 51112 MCN



STUBBY IMPACT WRENCH	
Length	108 mm
Bolt Diameter	16 mm
Square Drive	1/2"
Max. Torque	1200 Nm
Free Speed	9.500 Rpm
Air Consumption	180 l/min
Air Inlet	1/4"
Hose Diameter	10 mm
Working Pressure	90 psi (6.2 atü)
Weight	1.3 kg
Box Quantity	10 pcs



### OPC 51212 MCN 1/2" IMPACT WRENCH



MECHONEER IMPACT MECHANISM	
Length	172 mm
Bolt Diameter	22 mm
Square Drive	1/2"
Max. Torque	1.850 Nm
Free Speed	7.500 Rpm
Air Consumption	200 l/min
Air Inlet	1/4"
Hose Diameter	10.00 mm
Working Pressure	90-115 psi (6.2-8.0 atü)
Weight	2 kg
Box Quantity	10 pcs

### OPC 51212 MCNL 1/2" IMPACT WRENCH



MECHONEER IMPACT MECHANISM	
Length	212 mm
Bolt Diameter	22 mm
Square Drive	1/2"
Max. Torque	1.850 Nm
Free Speed	7.500 Rpm
Air Consumption	200 l/min
Air Inlet	1/4"
Hose Diameter	10.00 mm
Working Pressure	90-115 psi (6.2-8.0 atü)
Weight	2.13 kg
Box Quantity	10 pcs

### OPC 51212C 1/2" IMPACT WRENCH



TWIN HAMMER	
Length	190 mm
Bolt Diameter	19 mm
Square Drive	1/2"
Max. Torque	1.359 Nm
Free Speed	7.500 Rpm
Air Consumption	180 l/min
Air Inlet	1/4"
Hose Diameter	10.00 mm
Working Pressure	90-115 psi (6.2-8.0 atü)
Weight	1.97 kg
Box Quantity	8 pcs

### OPC 51212CL 1/2" IMPACT WRENCH



TWIN HAMMER	
Length	240 mm
Bolt Diameter	19 mm
Square Drive	1/2"
Max. Torque	1.359 Nm
Free Speed	7.500 Rpm
Air Consumption	180 l/min
Air Inlet	1/4"
Hose Diameter	10.00 mm
Working Pressure	90-115 psi (6.2-8.0 atü)
Weight	2.10 kg
Box Quantity	8 pcs

### OPC 51234 MCN 3/4" IMPACT WRENCH



MECHONEER IMPACT MECHANISM	
Length	194 mm
Bolt Diameter	36 mm
Square Drive	3/4"
Max. Torque	2.600 Nm
Free Speed	5.500 Rpm
Air Consumption	240 l/min
Air Inlet	3/8"
Hose Diameter	13 mm
Working Pressure	90 psi (6.2 atü)
Weight	3.5 kg
Box Quantity	4 pcs

### OPC 51234 MCNL 3/4" IMPACT WRENCH



MECHONEER IMPACT MECHANISM	
Length	287 mm
Bolt Diameter	36 mm
Square Drive	3/4"
Max. Torque	2.600 Nm
Free Speed	5.500 Rpm
Air Consumption	240 l/min
Air Inlet	3/8"
Hose Diameter	13 mm
Working Pressure	90-115 psi (6.2-8.0 atü)
Weight	3.90 kg
Box Quantity	4 pcs

### OPC 51234C 3/4" IMPACT WRENCH



TWIN HAMMER	
Length	230 mm
Bolt Diameter	32 mm
Square Drive	3/4"
Max. Torque	1.900 Nm
Free Speed	5.500 Rpm
Air Consumption	235 l/min
Air Inlet	3/8"
Hose Diameter	10.00 mm
Working Pressure	90 psi (6.2 atü)
Weight	3.40 kg
Box Quantity	4 pcs

### OPC 51234CL 3/4" IMPACT WRENCH



TWIN HAMMER	
Length	330 mm
Bolt Diameter	32 mm
Square Drive	3/4"
Max. Torque	1.900 Nm
Free Speed	5.500 Rpm
Air Consumption	235 l/min
Air Inlet	3/8"
Hose Diameter	10.00 mm
Working Pressure	90 psi (6.2 atü)
Weight	3.90 kg
Box Quantity	4 pcs

### OPC 51310 MCN 1" IMPACT WRENCH



MECHONEER IMPACT MECHANISM	
Length	244 mm
Bolt Diameter	48 mm
Square Drive	1"
Max. Torque	3.120 Nm
Free Speed	4.300 Rpm
Air Consumption	630 l/min
Air Inlet	1/2"
Hose Diameter	13 mm
Working Pressure	90 psi (6.2 atü)
Weight	6.8 kg
Box Quantity	2 pcs

### OPC 51310 MCN L 1" IMPACT WRENCH



MECHONEER IMPACT MECHANISM	
Length	447 mm
Bolt Diameter	48 mm
Square Drive	1"
Max. Torque	3.120 Nm
Free Speed	4.300 Rpm
Air Consumption	650 l/min
Air Inlet	1/2"
Hose Diameter	13 mm
Working Pressure	90 psi (6.2 atü)
Weight	6.8 kg
Box Quantity	2 pcs

### OPT-P 625 3/4" IMPACT WRENCH



PIN HAMMER	
Length	248 mm
Bolt Diameter	27 mm
Square Drive	3/4"
Max. Torque	1.086 Nm
Free Speed	4.800 Rpm
Air Consumption	205 l/min
Air Inlet	1/4"
Hose Diameter	10.00 mm
Working Pressure	90 psi (6.2 atü)
Weight	4.90 kg
Box Quantity	4 pcs

### OPT-P 508E 3/4" IMPACT WRENCH



TWIN HAMMER	
Length	230 mm
Bolt Diameter	36 mm
Square Drive	3/4"
Max. Torque	1.646 Nm
Free Speed	4.500 Rpm
Air Consumption	215 l/min
Air Inlet	1/4"
Hose Diameter	11.00 mm
Working Pressure	90 psi (6.2 atü)
Weight	6.00 kg
Box Quantity	4 pcs



### OPT 600 3/4" IMPACT WRENCH



SINGLE HAMMER	
Length	243 mm
Bolt Diameter	22 mm
Square Drive	3/4"
Max. Torque	670 Nm
Free Speed	4.800 Rpm
Air Consumption	205 l/min
Air Inlet	1/4"
Hose Diameter	10.00 mm
Working Pressure	90 psi (6.2 atü)
Weight	4.80 kg
Box Quantity	4 pcs

### OPT 600K 3/4" IMPACT WRENCH SET



SINGLE HAMMER	
OPT 600	1 pc
Impact Wrench	8 pcs
BMC Box	1 pc
Impact Wrenches 3/4"	26-27-29-30-32 35-36-38.00 mm
Box Quantity:	2 pcs



### OPC 51134 3/4" IMPACT WRENCH



TWIN HAMMER	
Length	226 mm
Bolt Diameter	30 mm
Square Drive	3/4"
Max. Torque	1.200 Nm
Free Speed	5.000 Rpm
Air Consumption	320 l/min
Air Inlet	1/4"
Hose Diameter	13.00 mm
Working Pressure	90-115 psi (6.2-8.0 atü)
Weight	5.00 kg
Box Quantity	4 pcs





### OPT-P 317 1" IMPACT WRENCH



SWING HAMMER	
Length	285 mm
Bolt Diameter	40 mm
Square Drive	1"
Max. Torque	2400 Nm
Free Speed	4.200 Rpm
Air Consumption	600 l/min
Air Inlet	1/2"
Hose Diameter	13.00 mm
Working Pressure	6.3-8 atü
Weight	9.7 kg
Box Quantity	1 pc

### OPT-P 317L 1" IMPACT WRENCH



SWING HAMMER	
Length	430 mm
Bolt Diameter	40 mm
Square Drive	1"
Max. Torque	2.400 Nm
Free Speed	4.200 Rpm
Air Consumption	600 l/min
Air Inlet	1/2"
Hose Diameter	13.00 mm
Working Pressure	6.3-8 atü
Weight	10.7 kg
Box Quantity	1 pc

### OPT-P 560 1" IMPACT WRENCH



TWIN HAMMER	
Length	475 mm
Bolt Diameter	50 mm
Square Drive	1"
Max. Torque	3.661 Nm
Free Speed	3.000 Rpm
Air Consumption	425 l/min
Air Inlet	1/2"
Hose Diameter	13.00 mm
Working Pressure	90-115 psi (6.2-8 atü)
Weight	15.00 kg
Box Quantity	1 pc

### OPT-P 560L 1" IMPACT WRENCH



TWIN HAMMER	
Length	628 mm
Bolt Diameter	50 mm
Square Drive	1"
Max. Torque	3.661 Nm
Free Speed	3.000 Rpm
Air Consumption	425 l/min
Air Inlet	1/2"
Hose Diameter	13.00 mm
Working Pressure	90-115 psi (6.2-8 atü)
Weight	16.40 kg
Box Quantity	1 pc

### OPT-P 318 1" IMPACT WRENCH



TWIN HAMMER	
Length	300 mm
Bolt Diameter	45 mm
Square Drive	1"
Max. Torque	2.714 Nm
Free Speed	3.500 Rpm
Air Consumption	312 l/min
Air Inlet	1/2"
Hose Diameter	13.00 mm
Working Pressure	90-115 psi (6.2-8 atü)
Weight	9.20 kg
Box Quantity	2 pcs

### OPT-P 318L 1" IMPACT WRENCH



TWIN HAMMER	
Length	450 mm
Bolt Diameter	45 mm
Square Drive	1"
Max. Torque	2.714 Nm
Free Speed	3.500 Rpm
Air Consumption	312 l/min
Air Inlet	1/2"
Hose Diameter	13.00 mm
Working Pressure	90-115 psi (6.2-8 atü)
Weight	9.70 kg
Box Quantity	2 pcs

### OPT-P 560-12 1.5" IMPACT WRENCH



TWIN HAMMER	
Length	475 mm
Bolt Diameter	50 mm
Square Drive	1.5"
Max. Torque	4.068 Nm
Free Speed	3.000 Rpm
Air Consumption	425 l/min
Air Inlet	1/2"
Hose Diameter	13.00 mm
Working Pressure	90-115 psi (6.2-8 atü)
Weight	15.05 kg
Box Quantity	1 pc

### OPT-P 560-12L 1.5" IMPACT WRENCH



TWIN HAMMER	
Length	675 mm
Bolt Diameter	50 mm
Square Drive	1.5"
Max. Torque	4.068 Nm
Free Speed	3.000 Rpm
Air Consumption	425 l/min
Air Inlet	1/2"
Hose Diameter	13.00 mm
Working Pressure	90-115 psi (6.2-8 atü)
Weight	16.70 kg
Box Quantity	1 pc

### OPT-P 418 1" IMPACT WRENCH



SWING HAMMER	
Length	310 mm
Bolt Diameter	55 mm
Square Drive	1"
Max. Torque	3.400 Nm
Free Speed	3.000 Rpm
Air Consumption	600 l/min
Air Inlet	1/2"
Hose Diameter	13.00 mm
Working Pressure	6.3-8 atü
Weight	13.8 kg
Box Quantity	1 pc

### OPT-P 418L 1" IMPACT WRENCH



SWING HAMMER	
Length	430 mm
Bolt Diameter	55 mm
Square Drive	1"
Max. Torque	3.400 Nm
Free Speed	3.000 Rpm
Air Consumption	600 l/min
Air Inlet	1/2"
Hose Diameter	13.00 mm
Working Pressure	6.3-8 atü
Weight	14.60 kg
Box Quantity	1 pc

### OPT-P 560-12GX 1.5" IMPACT WRENCH



TWIN HAMMER	
Length	490 mm
Bolt Diameter	56 mm
Square Drive	1.5"
Max. Torque	6779 Nm
Free Speed	3000 Rpm
Air Consumption	600 l/min
Air Inlet	1/2"
Hose Diameter	19 mm
Working Pressure	90 psi (6.2 atü)
Weight	14.90 kg
Box Quantity	1 pc

### OPT-P 560-12GXL 1.5" IMPACT WRENCH



TWIN HAMMER	
Length	625 mm
Bolt Diameter	56 mm
Square Drive	1.5"
Max. Torque	6779 Nm
Free Speed	3000 Rpm
Air Consumption	600 l/min
Air Inlet	1/2"
Hose Diameter	19 mm
Working Pressure	90 psi (6.2 atü)
Weight	15 kg
Box Quantity	1 pc



### OPT 367 1/4" RATCHET WRENCH



1/4" RATCHET WRENCH	
Length:	165 mm
Bolt Diameter:	8 mm
Square Drive:	1/4"
Max. Torque:	36 Nm
Free Speed:	240 Rpm
Air Consumption:	80 l/min
Air Inlet:	1/4"
Hose Diameter:	8.00 mm
Working Pressure:	90 psi (6.2 atü)
Weight:	1.00 kg
Box Quantity:	20 pcs

### OPT 378 3/8" RATCHET WRENCH



3/8" RATCHET WRENCH	
Length:	210 mm
Bolt Diameter:	12 mm
Square Drive:	3/8"
Max. Torque:	68 Nm
Free Speed:	160 Rpm
Air Consumption:	85 l/min
Air Inlet:	1/4"
Hose Diameter:	8.00 mm
Working Pressure:	90 psi (6.2 atü)
Weight:	1.25 kg
Box Quantity:	20 pcs

### OPT 650B 1/2" RATCHET WRENCH



1/2" RATCHET WRENCH	
Length:	210 mm
Bolt Diameter:	12 mm
Square Drive:	1/2"
Max. Torque:	78 Nm
Free Speed:	165 Rpm
Air Consumption:	90 l/min
Air Inlet:	1/4"
Hose Diameter:	8.00 mm
Working Pressure:	90 psi (6.2 atü)
Weight:	1.25 kg
Box Quantity:	20 pcs

### OPT-P 450A 1/2" RATCHET WRENCH



1/2" RATCHET WRENCH	
Length:	210 mm
Bolt Diameter:	12 mm
Square Drive:	1/2"
Max. Torque:	68 Nm
Free Speed:	150 Rpm
Air Consumption:	150 l/min
Air Inlet:	1/4"
Hose Diameter:	8.00 mm
Working Pressure:	90 psi (6.2 atü)
Weight:	1.20 kg
Box Quantity:	20 pcs

### OPT-P 389 1/2" RATCHET WRENCH



1/2" RATCHET WRENCH	
Length:	318 mm
Bolt Diameter:	14 mm
Square Drive:	1/2"
Max. Torque:	244 Nm
Free Speed:	300 Rpm
Air Consumption:	130 l/min
Air Inlet:	1/4"
Hose Diameter:	10 mm
Working Pressure:	90 psi (6.2 atü)
Weight:	1.3 kg
Box Quantity:	20 pcs

### OPC 55214 1/2" RATCHET WRENCH



1/2" RATCHET WRENCH	
Length:	266 mm
Bolt Diameter:	12 mm
Square Drive:	1/2"
Max. Torque:	70 Nm
Free Speed:	300 Rpm
Air Consumption:	180 l/min
Air Inlet:	1/4"
Hose Diameter:	10.00 mm
Working Pressure:	90-115 psi (6.2-8.0 atü)
Weight:	0.88 kg
Box Quantity:	20 pcs

### OPT-P 450C 1/2" IMPACT WRENCH 90°



1/2" IMPACT WRENCH 90°	
Length	335 mm
Bolt Diameter	16 mm
Square Drive	1/2"
Max. Torque	280 Nm
Free Speed	6.000 Rpm
Air Consumption	175 l/min
Air Inlet	1/4"
Hose Diameter	10.00 mm
Working Pressure	6.3-8.0 atü
Weight	2.0 kg
Box Quantity	10 pcs

### OPT-P 398 1/2" IMPACT WRENCH 90°



1/2" IMPACT WRENCH 90°	
Length	350 mm
Bolt Diameter	10 mm
Square Drive	1/2"
Max. Torque	240 Nm
Free Speed	3.500 Rpm
Air Consumption	220 l/min
Air Inlet	1/4"
Hose Diameter	10.00 mm
Working Pressure	90-115 psi (6.2-8.0 atü)
Weight	2.0 kg
Box Quantity	10 pcs

### OPT 232 10 MM DRILL REVERSIBLE



COMPOSITE BODY	
Length:	177 mm
Chuck Size:	10 mm
Spindle Thread:	3/8 24 UNF
Free Speed:	1800 Rpm
Air Consumption:	270 l/min
Air Inlet:	1/4"
Hose Diameter:	10.00 mm
Working Pressure:	90 psi (6.2 atü)
Weight:	1.30 kg
Box Quantity:	10 pcs

### OPT 230 10 MM DRILL NONREVERSIBLE



COMPOSITE BODY	
Length:	177 mm
Chuck Size:	10 mm
Spindle Thread:	3/8 24 UNF
Free Speed:	2.200 Rpm
Air Consumption:	270 l/min
Air Inlet:	1/4"
Hose Diameter:	10.00 mm
Working Pressure:	90 psi (6.2 atü)
Weight:	1.30 kg
Box Quantity:	10 pcs

### OPT 360K 3/8" CIRCIR MOTORU SET



3/8" CIRCIR MOTORU SET	
Length:	200 mm
Bolt Diameter:	10 mm
Square Drive:	3/8"
Max. Torque:	40 Nm
Free Speed:	450 Rpm
Air Consumption:	80 l/min
Air Inlet:	1/4"
Hose Diameter:	8.00 mm
Working Pressure:	90-115 psi (6.2-8.0 atü)
Weight:	0.55 kg
Box Quantity:	20 pcs

### OSA-TW3135 DIGITAL TORQUE ARM 3/8"



DIGITAL TORQUE ARM 3/8"	
3/8" 10-135 Nm DIGITAL TORQUE ARM	
Length 400 mm	

### OPT 232A 10 MM DRILL REVERSIBLE



METAL BODY	
Length:	177 mm
Chuck Size:	10 mm
Spindle Thread:	3/8 24 UNF
Free Speed:	1800 Rpm
Air Consumption:	270 l/min
Air Inlet:	1/4"
Hose Diameter:	10.00 mm
Working Pressure:	90 psi (6.2 atü)
Weight:	1.30 kg
Box Quantity:	10 pcs

### OPC 20201C 10 MM DRILL REVERSIBLE



FEATHER TRIGGER CONTROL	
Length:	185 mm
Chuck Size:	10 mm
Spindle Thread:	3/8 24 UNF
Free Speed:	1.800 Rpm
Noise Level:	83 dB (A)
Air Consumption:	113 l/min
Air Inlet:	1/4"
Hose Diameter:	10.00 mm
Working Pressure:	90-115psi (6.2-8.0 atü)
Weight:	1.10 kg
Box Quantity:	10 pcs

### OSA-TW 2030X DIGITAL TORQUE ARM 1/4"



DIGITAL TORQUE ARM 1/4"	
1/4" 3-20 Nm DIGITAL TORQUE ARM	
Length 220 mm	

### OSA-TW4340 DIGITAL TORQUE ARM 1/2"



DIGITAL TORQUE ARM 1/2"	
1/2" 34-340 Nm DIGITAL TORQUE ARM	
Length 770 mm	

### OPC 20202 10 MM DRILL REVERSIBLE



10 MM REVERSIBLE DRILL	
Length:	176 mm
Chuck Size:	10 mm
Spindle Thread:	3/8 24 UNF
Free Speed:	1.500 Rpm
Noise Level:	83 dB (A)
Air Consumption:	150 l/min
Air Inlet:	1/4"
Hose Diameter:	10.00 mm
Power:	0.30 kW
Working Pressure:	90-115psi (6.2-8.0 atü)
Weight:	1.39 kg
Box Quantity:	10 pcs

### OPT-P 130 6.5 MM DRILL



6.5 MM DRILL	
Length:	170 mm
Chuck Size:	6.5 mm
Spindle Thread:	3/8 24 UNF
Power:	0.20 kW
Free Speed:	4.000 Rpm
Air Consumption:	120 l/min
Air Inlet:	1/4"
Hose Diameter:	8.00 mm
Working Pressure:	90 psi (6.2 atü)
Weight:	0.90 kg
Box Quantity:	20 pcs

### OPT 237 13 MM DRILL REVERSIBLE



13 MM DRILL REVERSIBLE	
Length:	203 mm
Chuck Size:	13 mm
Spindle Thread:	24 UNF
Free Speed:	400 Rpm
Air Consumption:	250 l/min
Air Inlet:	1/4"
Hose Diameter:	10.00 mm
Working Pressure:	90 psi (6.2 atü)
Weight:	1.76 kg
Box Quantity:	10 pcs

### 13 MM REVERSIBLE DRILL



13 MM DRILL REVERSIBLE	
Length:	203 mm
Chuck Size:	13 mm
Spindle Thread:	24 UNF
Free Speed:	800 Rpm
Air Consumption:	250 l/min
Air Inlet:	1/4"
Hose Diameter:	10.00 mm
Working Pressure:	90 psi (6.2 atü)
Weight:	1.76 kg
Box Quantity:	10 pcs

### OPC 40206C SCREWDRIVER



SCREWDRIVER FEATHER TRIGGER CONTROL	
Length:	196 mm
Square Drive:	1/4"
Screw Diameter:	6 mm
Max. Torque:	13 Nm
Free Speed:	1.800 Rpm
Noise Level:	83 dB(A)
Hose Diameter:	10 mm
Air Inlet:	1/4"
Air Consumption:	174 l/min
Working Pressure:	90-115psi (6.2-8.0 atü)
Weight:	1.10 kg
Box Quantity:	10 pcs

### OPC 40208C SCREWDRIVER



SCREWDRIVER FEATHER TRIGGER CONTROL	
Length:	196 mm
Square Drive:	1/4"
Screw Diameter:	8 mm
Max. Torque:	16 Nm
Free Speed:	800 Rpm
Noise Level:	83 dB(A)
Hose Diameter:	10 mm
Air Inlet:	1/4"
Air Consumption:	113 l/min
Working Pressure:	90-115psi (6.2-8.0 atü)
Weight:	1.30 kg
Box Quantity:	10 pcs

### OPT 709-R 10 MM DRILL 90°



10 MM DRILL 90°	
Length:	210 mm
Height:	90 mm
Chuck Size:	10 mm
Spindle Thread:	3/8 24 UNF
Free Speed:	1.500 Rpm
Air Consumption:	113 l/min
Air Inlet:	1/4"
Hose Diameter:	10.00 mm
Working Pressure:	90 psi (6.2 atü)
Weight:	1.10 kg
Box Quantity:	10 pcs

### OPT 113 10 MM DRILL



10 MM DRILL	
Length:	210 mm
Chuck Size:	10 mm
Spindle Thread:	3/8 24 UNF
Free Speed:	4.500 Rpm
Air Consumption:	210 l/min
Air Inlet:	1/4"
Hose Diameter:	10.00 mm
Working Pressure:	90 psi (6.2 atü)
Weight:	1.20 kg
Box Quantity:	10 pcs

### OPT 4080-6 SCREWDRIVER



6 MM SCREWDRIVER	
Length:	190 mm
Square Drive:	1/4"
Screw Diameter:	6 mm
Max. Torque:	4-8 Nm
Free Speed:	1.800 Rpm
Working Pressure:	90-115psi (6.2-8.0 atü)
Hose Diameter:	10 mm
Air Inlet:	1/4"
Air Consumption:	170 l/min
Weight:	1.10 kg
Box Quantity:	10 pcs

### OPT 4080-8 SCREWDRIVER



8 MM SCREWDRIVER	
Length:	216 mm
Square Drive:	1/4"
Screw Diameter:	8 mm
Max. Torque:	4-11 Nm
Free Speed:	800 Rpm
Hose Diameter:	10 mm
Air Inlet:	1/4"
Air Consumption:	174 l/min
Working Pressure:	90-115psi (6.2-8.0 atü)
Weight:	1.30 kg
Box Quantity:	10 pcs

### OPT 208 6.5 MM DRILL



6.5 MM DRILL	
Length:	150 mm
Chuck Size:	6.5 mm
Spindle Thread:	3/8 24 UNF
Free Speed:	6.500 Rpm
Air Consumption:	170 l/min
Air Inlet:	1/4"
Hose Diameter:	10.00 mm
Working Pressure:	90 psi (6.2 atü)
Weight:	0.60 kg
Box Quantity:	20 pcs

### OPT 239 16 MM DRILL



16 MM DRILL REVERSIBLE	
Length:	328 mm
Chuck Size:	16 mm
Spindle Thread:	3/8 24 UNF
Free Speed:	800 Rpm
Air Consumption:	350 l/min
Air Inlet:	3/8"
Hose Diameter:	13.00 mm
Working Pressure:	90 psi (6.2 atü)
Weight:	3.6 kg
Box Quantity:	4 pcs

### OPT-P 4250 SCREWDRIVER



SCREWDRIVER - IMPACT DRIVE	
Length:	170 mm
Square Drive:	1/4"
Screw Diameter:	8 mm
Max. Torque:	50 Nm
Free Speed:	3.000 Rpm
Air Consumption:	280 l/min
Air Inlet:	1/4"
Hose Diameter:	9.50 mm
Working Pressure:	90 psi (6.2 atü)
Weight:	1.10 kg
Box Quantity:	20 pcs

### OPC 48116 SCREWDRIVER



SCREWDRIVER - IMPACT DRIVE	
Length:	140 mm
Square Drive:	1/4"
Screw Diameter:	6 mm
Max. Torque:	40 Nm
Free Speed:	12.000 Rpm
Air Consumption:	190 l/min
Air Inlet:	1/4"
Hose Diameter:	8.00 mm
Working Pressure:	90 psi (6.2 atü)
Weight:	0.90 kg
Box Quantity:	20 pcs



### OPT-P 766 SCREWDRIVER



ADJUSTABLE TORQUE	
Length:	230 mm
Square Drive:	1/4"
Screw Diameter:	6 mm
Max. Torque:	9 Nm
Free Speed:	1.800 Rpm
Air Consumption:	170 l/min
Air Inlet:	1/4"
Hose Diameter:	9.50 mm
Working Pressure:	90 psi (6.2 atü)
Weight:	1.33 kg
Box Quantity:	10 pcs

### OPT-P 768 SCREWDRIVER



ADJUSTABLE TORQUE	
Length:	250 mm
Square Drive:	1/4"
Screw Diameter:	8 mm
Max. Torque:	12 Nm
Free Speed:	800 Rpm
Air Consumption:	170 l/min
Air Inlet:	1/4"
Hose Diameter:	9.50 mm
Working Pressure:	90 psi (6.2 atü)
Weight:	1.43 kg
Box Quantity:	10 pcs

### OPC 44208 SCREWDRIVER



ADJUSTABLE TORQUE	
Length:	215 mm
Square Drive:	1/4"
Screw Diameter:	4.1-7.0 mm
Torque:	1.5-9.3 Nm
Free Speed:	550 Rpm
Air Consumption:	300 l/min
Air Inlet:	1/4"
Hose Diameter:	9.50 mm
Working Pressure:	90 psi (6.2 atü)
Weight:	0.77 kg
Box Quantity:	8 pcs

### OPC 44209 SCREWDRIVER



ADJUSTABLE TORQUE	
Length:	215 mm
Square Drive:	1/4"
Screw Diameter:	5mm
Torque:	5-28 Nm
Free Speed:	250 Rpm
Air Consumption:	300 l/min
Air Inlet:	1/4"
Hose Diameter:	9.50 mm
Working Pressure:	90 psi (6.2 atü)
Weight:	0.77 kg
Box Quantity:	8 pcs

### OPT-P 726 SCREWDRIVER



ADJUSTABLE TORQUE	
Length:	250 mm
Square Drive:	1/4"
Screw Diameter:	6 mm
Max. Torque:	8 Nm
Free Speed:	1.800 Rpm
Air Consumption:	170 l/min
Air Inlet:	1/4"
Hose Diameter:	9.50 mm
Working Pressure:	90 psi (6.2 atü)
Weight:	1.00 kg
Box Quantity:	20 pcs

### OPC 44204 SCREWDRIVER



ADJUSTABLE TORQUE	
Length:	180 mm
Square Drive:	1/4"
Screw Diameter:	2.2-4.2 mm
Torque:	0.2-1.5 Nm
Free Speed:	2.200 Rpm
Air Consumption:	280 l/min
Air Inlet:	1/4"
Hose Diameter:	9.50 mm
Working Pressure:	90 psi (6.2 atü)
Weight:	0.43 kg
Box Quantity:	8 pcs

### OPC 44205 SCREWDRIVER



ADJUSTABLE TORQUE	
Length:	180 mm
Square Drive:	1/4"
Screw Diameter:	2.8-5.0 mm
Torque:	0.48-2.9 Nm
Free Speed:	1.000 Rpm
Air Consumption:	280 l/min
Air Inlet:	1/4"
Hose Diameter:	9.50 mm
Working Pressure:	90 psi (6.2 atü)
Weight:	0.43 kg
Box Quantity:	8 pcs

### OPC 44206 SCREWDRIVER



ADJUSTABLE TORQUE	
Length:	215 mm
Square Drive:	1/4"
Screw Diameter:	2.9-6.0 mm
Torque:	0.7-5.0 Nm
Free Speed:	1.400 Rpm
Air Consumption:	300 l/min
Air Inlet:	1/4"
Hose Diameter:	9.50 mm
Working Pressure:	90 psi (6.2 atü)
Weight:	0.77 kg
Box Quantity:	8 pcs



### OPT 4080-D SCREWDRIVER



#### SCREWDRIVER DIRECT DRIVE

Length:	183 mm
Square Drive:	1/4"
Screw Diameter:	6 mm
Max. Torque:	9 Nm
Free Speed:	1.800 Rpm
Air Consumption:	270 l/min
Air Inlet:	1/4"
Hose Diameter:	9.50 mm
Working Pressure:	90 psi (6.2 atü)
Weight:	1.10 kg
Box Quantity:	10 pcs

### OPT 402 SCREWDRIVER



#### IMPACT DRIVE

Length:	187 mm
Square Drive:	1/4"
Screw Diameter:	5 mm
Max. Torque:	6 Nm
Free Speed:	10.000 Rpm
Air Consumption:	125 l/min
Air Inlet:	1/4"
Hose Diameter:	9.50 mm
Working Pressure:	90 psi (6.2 atü)
Weight:	0.90 kg
Box Quantity:	20 pcs

### OPC 21808 TAPPING MACHINE



#### TAPPING MACHINE

Length:	166 mm
Collet Size:	3-8 mm
Max. Torque:	20 Nm
Free Speed:	500 Rpm
Air Consumption:	150 l/min
Air Inlet:	3/8"
Hose Diameter:	13.00 mm
Working Pressure:	90 psi (6.2 atü)
Weight:	1.80 kg
Standard Acc.:	M8 Collet
Box Quantity:	4 pcs

### OPC 21812 TAPPING MACHINE



#### TAPPING MACHINE

Length:	195 mm
Collet Size:	3-12 mm
Max. Torque:	50 Nm
Free Speed:	300 Rpm
Air Consumption:	220 l/min
Air Inlet:	3/8"
Hose Diameter:	13.00 mm
Working Pressure:	90 psi (6.2 atü)
Weight:	3.00 kg
Standard Acc.:	M12 Collet
Box Quantity:	4 pcs

### OPT 842 SCREWDRIVER



#### SCREWDRIVER

Length:	230 mm
Square Drive:	1/4"
Screw Diameter:	6 mm
Max. Torque:	4-8 Nm
Free Speed:	1.800 Rpm
Air Consumption:	170 l/min
Air Inlet:	1/4"
Hose Diameter:	9.50 mm
Working Pressure:	90 psi (6.2 atü)
Weight:	1.16 kg
Box Quantity:	10 pcs

### OPT 843 SCREWDRIVER



#### SCREWDRIVER

Length:	240 mm
Square Drive:	1/4"
Screw Diameter:	8 mm
Max. Torque:	4-11 Nm
Free Speed:	800 Rpm
Air Consumption:	110 l/min
Air Inlet:	1/4"
Hose Diameter:	9.50 mm
Working Pressure:	90 psi (6.2 atü)
Weight:	1.26 kg
Box Quantity:	10 pcs

### OPT-P KC 12-3 TAPPING MACHINE



#### TAPPING MACHINE

Length:	200 mm
Collet Size:	3-12 mm
Free Speed:	400 Rpm
Air Consumption:	240 l/min
Air Inlet:	1/4"
Hose Diameter:	11.00 mm
Working Pressure:	90 psi (6.2 atü)
Weight:	1.48 kg
Box Quantity:	1 pc

### OPT-P KC 16-3 TAPPING MACHINE



#### TAPPING MACHINE

Length:	200 mm
Collet Size:	3-16 mm
Free Speed:	300 Rpm
Air Consumption:	285 l/min
Air Inlet:	3/8"
Hose Diameter:	11.00 mm
Working Pressure:	90 psi (6.2 atü)
Weight:	3.18 kg
Box Quantity:	1 pc

### OPT 304 SCREWDRIVER



#### SCREWDRIVER

Length:	235 mm
Square Drive:	1/4"
Screw Diameter:	4 mm
Max. Torque:	1.3-2.4 Nm
Free Speed:	1.500 Rpm
Air Consumption:	113 l/min
Air Inlet:	1/4"
Hose Diameter:	8.00 mm
Working Pressure:	90 psi (6.2 atü)
Weight:	0.66 kg
Box Quantity:	10 pcs

### OPT-P 304-B SCREWDRIVER



#### PUSH-START SCREWDRIVER

Length:	230 mm
Square Drive:	1/4"
Screw Diameter:	5 mm
Max. Torque:	1.3-2.4 Nm
Free Speed:	1.500 Rpm
Air Consumption:	130 l/min
Air Inlet:	1/4"
Hose Diameter:	9.50 mm
Working Pressure:	90 psi (6.2 atü)
Weight:	0.60 kg
Box Quantity:	10 pcs

### OPT-P KC 22-4 TAPPING MACHINE



#### TAPPING MACHINE

Length:	200 mm
Collet Size:	4-22 mm
Free Speed:	120-300 Rpm
Air Consumption:	285 l/min
Air Inlet:	3/8"
Hose Diameter:	11.00 mm
Working Pressure:	90 psi (6.2 atü)
Weight:	3.82 kg
Box Quantity:	1 pc



### OPT-P 3-12K TAPPING MACHINE

TAPPING MACHINE	
Capacity:	M3-M12
Free Speed:	400 Rpm
Working Distance:	Rmax=1400 mm Rmin=200 mm
Weight:	18 kg

#### Standard Accessories

- Pneumatic tapping tool
- Parallel reaction arm
- Fixing base
- FRL unit
- Radial arm - increases working distance by 500 mm
- Spare tapping chucks M3-M4-M6-M8-M10-M12



### OPT-P 3-16K TAPPING MACHINE

TAPPING MACHINE	
Capacity:	M3-M16
Free Speed:	300 Rpm
Working Distance:	Rmax=1400 mm Rmin=200 mm
Weight:	20 kg

#### Standard Accessories

- Pneumatic tapping tool
- Parallel reaction arm
- Fixing base
- FRL unit
- Radial arm - increases working distance by 500 mm
- Spare tapping chucks M6-M8-M10-M12-M14-M16



### OPT-P 4-22K TAPPING MACHINE

TAPPING MACHINE	
Capacity:	M4-M22
Free Speed:	120-300 Rpm
Working Distance:	Rmax=1400 mm Rmin=200 mm
Weight:	22 kg

#### Standard Accessories

- Pneumatic tapping tool
- Parallel reaction arm
- Fixing base
- FRL unit
- Radial arm - increases working distance by 500 mm
- Spare tapping chucks M6-M8-M10-M12-M14-M16

### OPT-P 3-16K 90° TAPPING MACHINE



TAPPING MACHINE	
Capacity:	M3-M16
Free Speed:	300 Rpm
Working Distance:	Rmax=1400 mm Rmin=200 mm
Weight:	20 kg

#### Standard Accessories

- Pneumatic tapping tool
- Parallel reaction arm
- Fixing base
- FRL unit
- Radial arm - increases working distance by 500 mm
- 90° rotatable
- Spare tapping chucks M6-M8-M10-M12-M14-M16

### OPT-P 4-22K 90° TAPPING MACHINE



TAPPING MACHINE	
Capacity:	M4-M22
Free Speed:	120-300 Rpm
Working Distance:	Rmax=1400 mm Rmin=200 mm
Weight:	22 kg

#### Standard Accessories

- Pneumatic tapping tool
- Parallel reaction arm
- Fixing base
- FRL unit
- Radial arm - increases working distance by 500 mm
- 90° rotatable
- Spare tapping chucks M6-M8-M10-M12-M14-M16

### OPT-P HM32-K TAPPING MACHINE



TAPPING MACHINE	
Capacity:	M4-M32
Free Speed:	0-200 Rpm
Weight:	22 kg
Motor:	5 HP
Hydraulic Pressure:	140 Bar
Electric Input:	3mx380 V/50 Hz
Box Quantity:	1 pc

#### Standard Accessories

- Hydraulic tapping tool
- Telescopic reaction arm
- Fixing base
- 6 pcs tapping chucks
- Hydraulic motor, pump and case
- Electrical control circuit

### OSI 570 REACTION ARM

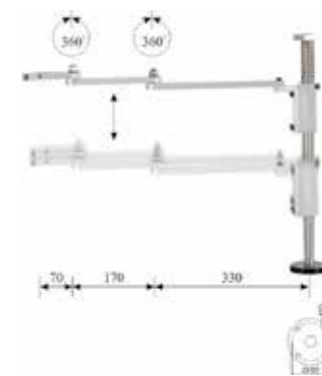

REACTION ARM	
Length	570 mm

### OSI 790 REACTION ARM



REACTION ARM	
Length	790 mm



### OPT 86032 NAILER 32 MM



NAILER	
Nail Size:	10-32 mm
Size:	240x60x165 mm
Length:	220 mm
Working Pressure:	5-7 bar
Weight:	125 kg
Applications:	Pallets, wooden boxes and chests, flooring, siding, furniture industry

### OPT 86050 NAILER 50 MM



NAILER	
Weight:	1.38 kg
Size:	250x238x57 mm
Capacity:	100 pcs
Working Pressure:	5-7 kgf/cm <sup>2</sup>
Length:	20x50 mm
Width and Thickness:	1,27x1,05 mm
Applications:	Pallets, wooden boxes and chests, flooring, siding, furniture industry

### OPT 86130 NAILER 130 MM



NAILER	
Size:	370x165x479 mm
Nail Length:	70x130 mm
Nail Dia.:	3,1x3,8 mm
Working Pressure:	6-8 kg/cm <sup>2</sup>
Weight:	6.3 kg
Capacity:	200 pcs
Head Dia.:	6.5-7.5 mm
Nail Type:	15° coil magazine
Applications:	Palet, ahşap kutu, sandık, zemin, siding, döşeme ve kaplama,

### OPT 8016 STAPLER GUN



STAPLER GUN	
Length:	240 mm
Wire Size:	8X4-8X16
Air Consumption:	60 l/min
Air Inlet:	1/4"
Hose Diameter:	8.00 mm
Working Pressure:	90 psi (6.2 atü)
Weight:	1.00 kg
Box Quantity:	10 pcs

### OPT 86055 NAILER 55 MM



NAILER	
Weight:	2.75 kg
Size:	270x283x131 mm
Capacity:	300-400 pcs
Working Pressure:	6-8 kgf/cm <sup>2</sup>
Nail Type:	15° coil magazine
Width:	115 mm
Nail Dia.:	2.1-2.3 mm
Head Dia.:	5.0-5.7 mm (.197"-.224")
Length:	25-57 mm (1" - 2-1/4")
Applications:	Pallets, wooden boxes and chests, flooring, siding, furniture industry

### OPT 86064 NAILER 64 MM



NAILER	
Weight:	3.01 kg
Size:	318x267x95 mm
Capacity:	100 pcs
Working Pressure:	5-7 kgf/cm <sup>2</sup>
Length:	18-64 mm
Thickness:	2.2 mm
Applications:	Construction, farming, woodworking, furniture industry

### OPT-P 85235 PNEUMATIC CARTON STAPLER



Wire Stapler	
Height:	15-18 mm
Length:	34,7 mm
Tool	
Length:	300 mm
Height:	200 mm
Width:	100 mm
Weight:	1.59 kg
Hose Diameter:	8 mm
Working Pressure:	5-7 bar

### OPT-P 85335 PNEUMATIC CARTON STAPLER



Wire Stapler	
Height:	15-18mm
Length:	34,7 mm
Tool	
Length:	415 mm
Height:	220 mm
Width:	115 mm
Weight:	2.65 kg
Hose Diameter:	8 mm
Working Pressure:	5-7 bar

### OPT 86070 NAILER 70 MM



NAILER	
Weight:	3.80 kg
Size:	336x143x318 mm
Capacity:	300 pcs
Working Pressure:	6-8 kgf/cm <sup>2</sup>
Nail Type:	15° coil magazine
Nail Dia.:	2.3-2.9 mm (.090"-.113")
Head Dia.:	5.7-7.0 mm (.224"-.276")
Length:	45-70 mm (1-3/4"-2-3/4")
Applications:	Pallets, wooden boxes and chests, flooring, siding, furniture industry

### OPT 86090 NAILER 90 MM



NAILER	
Weight:	4.20 kg
Size:	347x137x348 mm
Capacity:	300 pcs
Working Pressure:	6-8 kgf/cm <sup>2</sup>
Nail Type:	15° coil magazine
Nail Dia.:	2.5-3.8 mm (.099"-.148")
Head Dia.:	6.5-7.7 mm (.256"-.303")
Length:	45-90 mm (1-3/4"-3-1/2")
Applications:	Pallets, wooden boxes and chests, flooring, siding, furniture industry

### OPT-P 85435 PNEUMATIC CARTON STAPLER



Wire Stapler	
Height:	18-22 mm
Length:	34,7 mm
Tool	
Length:	415 mm
Height:	220 mm
Width:	115 mm
Weight:	2.65 kg
Hose Diameter:	8 mm
Working Pressure:	5-7 bar

### OPT-P 85735J JUMBO CARTON STAPLER



Wire Stapler	
Height:	32-35 mm
Length:	32 mm
Tool	
Length:	360 mm
Height:	335 mm
Width:	174 mm
Weight:	6.00 kg
Hose Diameter:	8 mm
Working Pressure:	5-7 bar



## OPT-P 85135 MEKANİK KOLİ KAPAMA TABANCASI



Wire Stapler	
Height:	15 18 mm
Length:	34,7 mm
Tool	
Length:	360 mm
Height:	335 mm
Width:	174 mm
Weight:	6,00 kg

## OPT-P 200 STEEL STRAPPING TOOL



STEEL STRAPPING MACHINE	
Strapping Torque:	4.000 Nm
Size:	315X145X127 mm
Strap Width:	Max. 19 mm
Strap Thickness:	0.38mm-0.63mm
Sıkıştırma:	55%
Air Consumption:	180 l/min
Air Inlet:	1/4"
Hose Diameter:	10 mm
Working Pressure:	90-115 psi (6.2-8.0 atü)
Weight:	4.85 kg
Box Quantity:	6 pcs

## OPT 310 SHEET METAL CUTTER



SHEET METAL CUTTER	
Length:	290 mm
Cutting Capacity:	Steel 1.20 mm Aluminum 1.60 mm
Free Speed:	2.600 Rpm
Hose Diameter:	10 mm
Air Inlet:	1/4"
Air Consumption:	113 l/min
Working Pressure:	90 psi (6.2 atü)
Weight:	1.05 kg
Box Quantity:	10 pcs

## OPT 330 SHEET METAL CUTTER



SHEET METAL CUTTER	
Length:	290 mm
Cutting Capacity:	Steel 1.20 mm Aluminum 1.60 mm
Free Speed:	2.600 Rpm
Hose Diameter:	10 mm
Air Inlet:	1/4"
Air Consumption:	113 l/min
Working Pressure:	90 psi (6.2 atü)
Weight:	1.15 kg
Box Quantity:	10 pcs

## OPT 1005 SIDE CUTTER



SIDE CUTTER	
Length:	140 mm
Cutting Capacity:	Iron 0.50 mm Copper 1.00 mm Aluminum 1.26 mm
Stroke:	10.0 mm
Hose Diameter:	9.50 mm
Air Inlet:	1/4"
Air Consumption:	85 l/min
Working Pressure:	90 psi (6.2 atü)
Weight:	0.14 kg
Box Quantity:	20 pcs

## OPT 1006 SIDE CUTTER



SIDE CUTTER	
Length:	160 mm
Cutting Capacity:	Iron 1.00 mm Copper 1.60 mm Aluminum 2.26 mm
Stroke:	10.0 mm
Hose Diameter:	9.50 mm
Air Inlet:	1/4"
Air Consumption:	95 l/min
Working Pressure:	90 psi (6.2 atü)
Weight:	0.20 kg
Box Quantity:	20 pcs

## OPT-P 690 NIBBLER



NIBBLER	
Length:	150 mm
Cutting Capacity:	Steel 1.20 mm Sheet Metal 1.60 mm Aluminum 2.00 mm
Kesme Hızı:	2.6 m/dk
Hose Diameter:	10 mm
Air Inlet:	1/4"
Air Consumption:	113 l/min
Working Pressure:	90 psi (6.2 atü)
Weight:	1.20 kg
Box Quantity:	20 pcs

## OPT 216 GLASS RUN CHANNEL CUTTER



GLASS RUN CHANNEL CUTTER	
Length:	200 mm
Stroke:	3.00 mm
Stroke Frequency:	20.000 bpm
Hose Diameter:	10 mm
Air Inlet:	1/4"
Air Consumption:	260 l/min
Working Pressure:	90 psi (6.2 atü)
Weight:	1.20 kg
Box Quantity:	20 pcs

## OPT 1007 SIDE CUTTER



SIDE CUTTER	
Length:	200 mm
Cutting Capacity:	Iron 2.00 mm Copper 2.60 mm Aluminum 3.26 mm
Stroke:	10.0 mm
Hose Diameter:	9.50 mm
Air Inlet:	1/4"
Air Consumption:	105 l/min
Working Pressure:	90 psi (6.2 atü)
Weight:	0.35 kg
Box Quantity:	10 pcs

## OPT 1008 SIDE CUTTER



SIDE CUTTER	
Length:	240 mm
Cutting Capacity:	Iron 2.90 mm Copper 3.30 mm Aluminum 3.26 mm Paslanmaz 2.00 mm
Stroke:	10.0 mm
Hose Diameter:	9.50 mm
Air Inlet:	1/4"
Air Consumption:	125 l/min
Working Pressure:	90 psi (6.2 atü)
Weight:	0.56 kg
Box Quantity:	10 pcs

## OPT 315 FILING MACHINE



FILING MACHINE	
Length:	165 mm
Stroke:	9.0 mm
Stroke Frequency:	3.700 spm
Air Consumption:	170 l/min
Air Inlet:	1/4"
Hose Diameter:	9.50 mm
Working Pressure:	90 psi (6.2 atü)
Weight:	1.51 kg
Box Quantity:	20 pcs

## OPT 315 LV FILING MACHINE



LOW VIBRATION FILING MACHINE	
Length:	270 mm
Free Speed:	12.000 Rpm
Stroke:	5.0 mm
Air Consumption:	210 l/min
Air Inlet:	1/4"
Hose Diameter:	8 mm
Working Pressure:	90 psi (6.2 atü)
Weight:	1.02 kg
Box Quantity:	10 pcs



### OPC 61119 DIE GRINDER



DIE GRINDER	
Length:	190 mm
Collet Size:	6 mm
Wheel Diameter:	30 mm
Power:	0.20 kW
Free Speed:	18.000 Rpm
Air Consumption:	220 l/min
Air Inlet:	1/4"
Hose Diameter:	10.00 mm
Working Pressure:	90 psi (6.2 atü)
Weight:	0.40 kg
Box Quantity:	50 pcs

### OPT-P 128 DIE GRINDER



DIE GRINDER	
Length:	156 mm
Collet Size:	6 mm
Wheel Diameter:	32 mm
Free Speed:	22.000 Rpm
Air Consumption:	300 l/min
Air Inlet:	1/4"
Hose Diameter:	8.00 mm
Working Pressure:	90 psi (6.2 atü)
Weight:	0.7 kg
Box Quantity:	10 pcs

### OPT 124 DIE GRINDER 90°



DIE GRINDER 90°	
Length:	160 mm
Collet Size:	6 mm
Wheel Diameter:	38 mm
Free Speed:	20.000 Rpm
Air Consumption:	178 l/min
Air Inlet:	1/4"
Hose Diameter:	9.50 mm
Working Pressure:	90 psi (6.2 atü)
Weight:	0.56 kg
Box Quantity:	12 pcs

### OPT-P 124 N DIE GRINDER 90°



DIE GRINDER 90°	
Length:	180 mm
Collet Size:	6 mm
Wheel Diameter:	38 mm
Free Speed:	18.000 Rpm
Air Consumption:	210 l/min
Air Inlet:	1/4"
Hose Diameter:	10 mm
Working Pressure:	90 psi (6.2 atü)
Weight:	0.56 kg
Box Quantity:	20 pcs

### OPT-P 120 DIE GRINDER



DIE GRINDER	
Length:	155 mm
Collet Size:	6 mm
Wheel Diameter:	38 mm
Free Speed:	25.000 Rpm
Air Consumption:	178 l/min
Air Inlet:	1/4"
Hose Diameter:	9.50 mm
Working Pressure:	90 psi (6.2 atü)
Weight:	0.14 kg
Box Quantity:	12 pcs

### OPT-P 120N DIE GRINDER



DIE GRINDER	
Length:	180 mm
Collet Size:	6 mm
Wheel Diameter:	50 mm
Power:	0.5 HP / 0.368 kW
Free Speed:	22.000 Rpm
Air Consumption:	180 l/min
Air Inlet:	1/4"
Hose Diameter:	10 mm
Working Pressure:	90 psi (6.2 atü)
Weight:	0.6 kg
Box Quantity:	20 pcs

### OPT 126 PISTOL TYPE DIE GRINDER



DIE GRINDER	
Length:	190 mm
Collet Size:	6 mm
Wheel Diameter:	30 mm
Power:	0.20 kW
Free Speed:	18.000 Rpm
Air Consumption:	220 l/min
Air Inlet:	1/4"
Hose Diameter:	10.00 mm
Working Pressure:	90 psi (6.2 atü)
Weight:	0.40 kg
Box Quantity:	50 pcs

### OPT-P 106-2 TYRE BUFFER



BLIND RIVET GUN SET	
Length:	190 mm
Collet Size:	6 mm
Wheel Diameter:	42 mm
Free Speed:	4.000 Rpm
Air Consumption:	120 l/min
Air Inlet:	1/4"
Hose Diameter:	9.50 mm
Working Pressure:	90 psi (6.2 atü)
Weight:	0.82 kg
Box Quantity:	10 pcs
Box Quantity:	50 pcs

### OPT 127 DIE GRINDER



DIE GRINDER	
Length:	170 mm
Collet Size:	6 mm
Wheel Diameter:	38 mm
Free Speed:	22.000 Rpm
Air Consumption:	185 l/min
Air Inlet:	1/4"
Hose Diameter:	9.50 mm
Working Pressure:	90 psi (6.2 atü)
Weight:	0.74 kg
Box Quantity:	20 pcs

### OPT 121 DIE GRINDER



DIE GRINDER	
Length:	135 mm
Collet Size:	6 mm
Wheel Diameter:	30 mm
Free Speed:	22.000 Rpm
Air Consumption:	165 l/min
Air Inlet:	1/4"
Hose Diameter:	9.50 mm
Working Pressure:	90 psi (6.2 atü)
Weight:	0.35 kg
Box Quantity:	20 pcs

### OPT-P 515 DIE GRINDER



DIE GRINDER	
Length:	200 mm
Collet Size:	6 mm
Wheel Diameter:	38 mm
Free Speed:	22.000 Rpm
Air Consumption:	225 l/min
Air Inlet:	1/4"
Hose Diameter:	9.50 mm
Working Pressure:	90 psi (6.2 atü)
Weight:	0.56 kg
Box Quantity:	20 pcs

### OPT 4 DIE GRINDER SET



DIE GRINDER SET	
	1 pc. OPT 4 Die Grinder
	1 pc. 1/8" Collet
	1 pc. 1/4" Collet
	10 pcs. Various Wheels
	1 pc. BMC Box
	Box Quantity 20 pcs

### OPC 62050 DIE GRINDER



DIE GRINDER	
Length:	230 mm
Collet Size:	6 mm
Wheel Diameter:	30 mm
Power:	0.368 kW
Free Speed:	21.000 Rpm
Air Consumption:	120 l/min
Air Inlet:	1/4"
Hose Diameter:	10.00 mm
Working Pressure:	90 psi (6.2 atü)
Weight:	0.8 kg
Box Quantity:	30 pcs

### OPC 62075 DIE GRINDER



DIE GRINDER	
Length:	350 mm
Collet Size:	6 mm
Wheel Diameter:	40 mm
Power:	0.368 kW
Free Speed:	18.000 Rpm
Air Consumption:	198 l/min
Air Inlet:	1/4"
Hose Diameter:	10.00 mm
Working Pressure:	90 psi (6.2 atü)
Weight:	1.6 kg
Box Quantity:	30 pcs

### OPC 68150 150 MM STRAIGHT GRINDER



STRAIGHT GRINDER	
Length:	540 mm
Wheel Diameter:	150 mm
Free Speed:	6.600 Rpm
Air Consumption:	930 l/min
Air Inlet:	3/8"
Hose Diameter:	16.00 mm
Working Pressure:	90 psi (6.2 atü)
Weight:	5.6 kg
Box Quantity:	1 pc

### OPT-P 100L 100 MM STRAIGHT GRINDER



STRAIGHT GRINDER	
Length:	414 mm
Wheel Diameter:	100x19x12,7
Free Speed:	9.500 Rpm
Air Consumption:	800 l/min
Air Inlet:	3/8"
Hose Diameter:	13.00 mm
Working Pressure:	90 psi (6.2 atü)
Weight:	2.3 kg
Box Quantity:	10 pcs

A01 EXTENSION  
A02 THICK WHEEL ADAPTOR  
OPTIONAL 93\$

### OPT-P 122S4 DIE GRINDER



DIE GRINDER	
Length:	306 mm
Collet Size:	6 mm
Wheel Diameter:	25 mm
Power:	0,35 kW
Free Speed:	24.000 Rpm
Air Consumption:	400 l/min
Air Inlet:	1/4"
Hose Diameter:	10.00 mm
Working Pressure:	90 psi (6.2 atü)
Weight:	0,90 kg
Box Quantity:	10 pcs

### OPT-P 122S5 DIE GRINDER



DIE GRINDER	
Length:	319 mm
Collet Size:	6 mm
Wheel Diameter:	38 mm
Free Speed:	22.000 Rpm
Air Consumption:	120 l/min
Air Inlet:	1/4"
Hose Diameter:	9.50 mm
Working Pressure:	90 psi (6.2 atü)
Weight:	1.05 kg
Box Quantity:	20 pcs

### OPT-P 940 ENGRAVING PEN



ENGRAVING PEN	
Length:	170 mm
Stroke:	1.2 mm
Blow per Minute:	42.000 bpm
Air Consumption:	60 l/min
Air Inlet:	1/4"
Hose Diameter:	8.00 mm
Working Pressure:	90-115 psi (6.2-8.0 atü)
Weight:	0.20 kg
Box Quantity:	20 pcs

### OPT-P 1503 MICRO DIE GRINDER



MICRO DIE GRINDER	
Length:	160 mm
Collet Size:	3 mm
Wheel Diameter:	18 mm
Free Speed:	60.000 Rpm
Air Consumption:	200 l/min
Air Inlet:	1/4"
Hose Diameter:	8.00 mm
Working Pressure:	90 psi (6.2 atü)
Weight:	0.110 kg
Box Quantity:	10 pcs

### OPT-P 122S6 DIE GRINDER



DIE GRINDER	
Length:	367 mm
Collet Size:	6 mm
Wheel Diameter:	45 mm
Free Speed:	14.600 Rpm
Power:	0,50 kW
Air Consumption:	600 l/min
Air Inlet:	3/8"
Hose Diameter:	10.00 mm
Working Pressure:	90 psi (6.2 atü)
Weight:	1.5 kg
Box Quantity:	10 pcs

### OPT-P 122S8 EXTENDED STRAIGHT GRINDER



EXTENDED STRAIGHT GRINDER	
Length:	1050 mm
Wheel Diameter:	100x19x12.7
Free Speed:	9.000 Rpm
Air Consumption:	900 l/min
Air Inlet:	3/8"
Hose Diameter:	13.00 mm
Working Pressure:	90 psi (6.2 atü)
Weight:	5.4 kg
Box Quantity:	1 pc

### OPT-P 501 MICRO DIE GRINDER



MICRO DIE GRINDER	
Length:	155 mm
Collet Size:	3 mm
Wheel Diameter:	18.00 mm
Free Speed:	60.000 Rpm
Air Consumption:	120 l/min
Air Inlet:	1/4"
Hose Diameter:	6.50 mm
Working Pressure:	90 psi (6.2 atü)
Weight:	0.30 kg
Box Quantity:	20 pcs

### OPT-P 513 ANGLE MICRO DIE GRINDER



DIE GRINDER	
Length:	155 mm
Wheel Diameter:	18 mm
Free Speed:	23.000 Rpm
Air Consumption:	120 l/min
Air Inlet:	1/4"
Hose Diameter:	6.50 mm
Working Pressure:	90 psi (6.2 atü)
Weight:	0.30 kg
Box Quantity:	10 pcs



### OPT-P 1504 MICRO DIE GRINDER



MICRO DIE GRINDER	
Length:	180 mm
Collet Size:	3-6 mm
Wheel Diameter:	20 mm
Free Speed:	35.000 Rpm
Air Consumption:	200 l/min
Air Inlet:	1/4"
Hose Diameter:	8.00 mm
Working Pressure:	90 psi (6,2 atü)
Weight:	0.170 kg
Box Quantity:	10 ad

### OPT-P 1505 MICRO DIE GRINDER



MICRO DIE GRINDER	
Length:	175 mm
Collet Size:	3 mm
Wheel Diameter:	15 mm
Free Speed:	80.000 Rpm
Air Consumption:	250 l/min
Air Inlet:	1/4"
Hose Diameter:	8.00 mm
Working Pressure:	90 psi (6,2 atü)
Weight:	0.40 kg
Box Quantity:	10 ad

### OPC 60215 125 MM ANGLE GRINDER



125 MM ANGLE GRINDER	
Length:	264 mm
Wheel Diameter:	125 mm
Noise Level:	83 dB(A)
Free Speed:	11.000 Rpm
Power:	0.60 kW
Air Consumption:	320 l/min
Air Inlet:	3/8"
Hose Diameter:	13.00 mm
Working Pressure:	90-115 psi (6,2-8,0 atü)
Weight:	1.9 kg
Box Quantity:	9 pcs

### OPT-P 6115 125 MM ANGLE GRINDER



125 MM ANGLE GRINDER	
Length:	264 mm
Wheel Diameter:	125 mm
Free Speed:	11.000 Rpm
Power:	0.60 kW
Air Consumption:	630 l/min
Air Inlet:	3/8"
Hose Diameter:	13.00 mm
Working Pressure:	90-115 psi (6,2-8,0 atü)
Weight:	2.2 kg
Box Quantity:	10 pcs

### OPT-P 7301 FILING MACHINE



FILING MACHINE - SIDE TO SIDE	
Length:	205 mm
Stroke:	0,3 mm
Stroke Frequency:	15.000 spm
Air Consumption:	170 l/min
Air Inlet:	1/4"
Hose Diameter:	8.00 mm
Working Pressure:	90 psi (6,2 atü)
Weight:	0.305 kg
Box Quantity:	10 pcs

### OPT-P 7203 FILING MACHINE



FILING MACHINE - BACK AND FORTH	
Length:	200 mm
Stroke:	0,2 mm
Stroke Frequency:	35.000 spm
Air Consumption:	170 l/min
Air Inlet:	1/4"
Hose Diameter:	8.00 mm
Working Pressure:	90 psi (6,2 atü)
Weight:	0.190 kg
Box Quantity:	10 pcs

### OPT-P 6315 125 MM ANGLE GRINDER



125 MM ANGLE GRINDER	
Length:	262 mm
Wheel Diameter:	125 mm
Free Speed:	12.000 Rpm
Power:	960 kW / 1.3 hp
Air Consumption:	900 l/min
Air Inlet:	3/8"
Hose Diameter:	10.00 mm
Working Pressure:	6,3-8 atü
Weight:	1.9 kg
Box Quantity:	10 pcs

### OPT 505 100 MM PISTOL TYPE GRINDER



PISTOL TYPE GRINDER	
Length:	135 mm
Wheel Diameter:	100 mm
Free Speed:	15.000 Rpm
Air Consumption:	150 l/min
Air Inlet:	1/4"
Hose Diameter:	9.50 mm
Working Pressure:	90-115 psi (6,2-8,0 atü)
Weight:	1.1 kg
Box Quantity:	10 pcs

### OPT-P 7205 FILING MACHINE



FILING MACHINE - BACK AND FORTH	
Length:	200 mm
Stroke:	0,3 mm
Stroke Frequency:	30.000 spm
Air Consumption:	170 l/min
Air Inlet:	1/4"
Hose Diameter:	8.00 mm
Working Pressure:	90 psi (6,2 atü)
Weight:	0.190 kg
Box Quantity:	10 pcs

### OPT-P 7212 FILING MACHINE



FILING MACHINE - BACK AND FORTH	
Length:	200 mm
Stroke:	0,7 mm
Stroke Frequency:	28.000 spm
Air Consumption:	170 l/min
Air Inlet:	1/4"
Hose Diameter:	8.00 mm
Working Pressure:	90 psi (6,2 atü)
Weight:	0.190 kg
Box Quantity:	10 pcs

### OPT-P 125 50 MM ANGLE GRINDER



50 MM ANGLE GRINDER	
Length:	188 mm
Wheel Diameter:	50 mm
Free Speed:	15.000 Rpm
Air Consumption:	400 l/min
Air Inlet:	1/4"
Hose Diameter:	8.00 mm
Working Pressure:	90 psi (6,2 atü)
Weight:	0,7 kg
Box Quantity:	10 pcs

### OPC 60225 C 75 MM ANGLE GRINDER



75 MM ANGLE GRINDER	
Length:	290 mm
Wheel Diameter:	75 mm
Noise Level:	83 dB(A)
Free Speed:	16.000 Rpm
Air Consumption:	350 l/min
Air Inlet:	1/4"
Hose Diameter:	10.00 mm
Working Pressure:	90-115 psi (6,2-8,0 atü)
Weight:	1.3 kg
Box Quantity:	10 pcs

### OPT-P 6180 180 MM ANGLE GRINDER



180 MM ANGLE GRINDER	
Length:	392 mm
Wheel Diameter:	180 mm
Free Speed:	7.500 Rpm
Power:	1.00 kW
Air Consumption:	800 U/min
Air Inlet:	3/8"
Hose Diameter:	16.00 mm
Working Pressure:	90-115 psi (6.2-8.0 atü)
Weight:	3.3 kg
Box Quantity:	6 pcs

### OPT-P 509 180 MM ANGLE GRINDER



180 MM ANGLE GRINDER	
Length:	343 mm
Wheel Diameter:	180 mm
Free Speed:	7.000 Rpm
Power:	1.1 kW
Air Consumption:	340 U/min
Air Inlet:	3/8"
Hose Diameter:	13.00 mm
Working Pressure:	90-115 psi (6.2-8.0 atü)
Weight:	3.20 kg
Box Quantity:	6 pcs

### OPT-P 791 POLISHER



POLISHER	
Length:	343 mm
Wheel Diameter:	180 mm
Free Speed:	2.500 Rpm
Air Consumption:	340 U/min
Air Inlet:	1/2"
Hose Diameter:	13.00 mm
Working Pressure:	90-115 psi (6.2-8.0 atü)
Weight:	2.70 kg
Box Quantity:	10 pcs

### OPT-P 793 POLISHER



POLISHER	
Length:	343 mm
Wheel Diameter:	180 mm
Free Speed:	3.000 Rpm
Air Consumption:	220 U/min
Air Inlet:	3/8"
Hose Diameter:	13.00 mm
Working Pressure:	90-115 psi (6.2-8.0 atü)
Weight:	2.00 kg
Box Quantity:	10 pcs

### OPC 6218 180 MM ANGLE GRINDER



180 MM ANGLE GRINDER	
Length:	238.00 mm
Wheel Diameter:	180 mm
Free Speed:	7.000 Rpm
Power:	1.52 kW
Air Consumption:	1.590 U/min
Air Inlet:	3/8"
Hose Diameter:	16.00 mm
Working Pressure:	90-115 psi (6.2-8.0 atü)
Weight:	3.40 kg
Box Quantity:	4 pcs

### OPC 60218 180 MM ANGLE GRINDER



180 MM ANGLE GRINDER	
Length:	323 mm
Wheel Diameter:	180 mm
Free Speed:	7.500 Rpm
Power:	1.65 kW
Air Consumption:	1400 U/min
Air Inlet:	3/8"
Hose Diameter:	16.00 mm
Working Pressure:	90-115 psi (6.2-8.0 atü)
Weight:	3 kg
Box Quantity:	6 pcs

### OPC 60230 230 MM V-TYPE GRINDER



230 MM V-TYPE GRINDER	
Length:	238.00 mm
Wheel Diameter:	230 mm
Free Speed:	5.900 Rpm
Power:	2.00 kW
Air Consumption:	1.700 U/min
Air Inlet:	3/8"
Hose Diameter:	19.00 mm
Working Pressure:	90-115 psi (6.2-8.0 atü)
Weight:	3.80 kg
Box Quantity:	4 pcs

### OPT-P 799A POLISHER



POLISHER	
Length:	206 mm
Wheel Diameter:	150 mm
Free Speed:	3.500 Rpm
Air Consumption:	110 U/min
Air Inlet:	1/4"
Hose Diameter:	10.00 mm
Working Pressure:	90 psi (6.2 atü)
Weight:	1.0 kg
Box Quantity:	10 pcs





### OPC 6223D 150 MM ORBIT SANDER



150 MM SANDER	
Vibration:	< 2.5 mm
Orbit Diameter:	5 mm
Pad Diameter:	125-150 mm
Free Speed:	0-10.000 Rpm
Air Consumption:	151 l/min
Air Inlet:	1/4"
Hose Diameter:	11.00 mm
Working Pressure:	90-115 psi (6.2-8.0 atü)
Noise Level:	85 dB(A)
Weight:	1.30 kg
Box Quantity:	10 pcs

### OPC 62303B 150 MM ORBIT SANDER



150 MM SANDER	
Vibration:	2.5 mm
Orbit Diameter:	5 mm
Pad Diameter:	125-150 mm
Free Speed:	0-12.000 Rpm
Air Consumption:	151 l/min
Air Inlet:	1/4"
Hose Diameter:	11.00 mm
Working Pressure:	90-115 psi (6.2-8.0 atü)
Noise Level:	76 dB(A)
Weight:	0.78 kg
Box Quantity:	6 pcs

### OPT-P 701C COMPOSITE BELT SANDER



COMPOSITE BELT SANDER	
Length:	325 mm
Belt Size:	10x330 mm
Free Speed:	18.000 Rpm
Air Consumption:	270 l/min
Air Inlet:	1/4"
Hose Diameter:	10.00 mm
Working Pressure:	90-115 psi (6.2-8.0 atü)
Weight:	0.80 kg
Box Quantity:	10 pcs

### OPT-P 702C COMPOSITE BELT SANDER



COMPOSITE BELT SANDER	
Length:	399 mm
Belt Size:	20x520 mm
Free Speed:	18.000 Rpm
Power:	0.9 hp
Air Consumption:	210 l/min
Hose Diameter:	10.00 mm
Working Pressure:	90 psi (6.2)
Weight:	1.02 kg
Box Quantity:	10 pcs

### OPT-P 309B ORBIT SANDER



ORBIT SANDER VACUUM	
Vibration:	< 2 mm
Orbit Diameter:	5 mm
Pad Diameter:	125-150 mm
Free Speed:	0-12.000 Rpm
Air Consumption:	151 l/min
Air Inlet:	1/4"
Hose Diameter:	11.00 mm
Working Pressure:	90-115 psi (6.2-8.0 atü)
Weight:	0.78 kg
Box Quantity:	6 pcs

### OPT-P 309BW ORBIT SANDER



ORBIT SANDER NON-VACUUM	
Vibration:	< 2 mm
Orbit Diameter:	5 mm
Pad Diameter:	125-150 mm
Free Speed:	0-12.000 Rpm
Air Consumption:	151 l/min
Air Inlet:	1/4"
Hose Diameter:	11.00 mm
Working Pressure:	90-115 psi (6.2-8.0 atü)
Weight:	0.60 kg
Box Quantity:	10 pcs

### OPT-P 701 BELT SANDER



BELT SANDER	
Length:	280 mm
Belt Size:	10x330 mm
Free Speed:	19.000 Rpm
Air Consumption:	226 l/min
Air Inlet:	1/4"
Hose Diameter:	10.00 mm
Working Pressure:	90-115 psi (6.2-8.0 atü)
Weight:	0.80 kg
Box Quantity:	10 pcs

### OPT-P 702 BELT SANDER



BELT SANDER	
Length:	360 mm
Belt Size:	20x520 mm
Free Speed:	18.000 Rpm
Air Consumption:	255 l/min
Air Inlet:	1/4"
Hose Diameter:	10.00 mm
Working Pressure:	90-115 psi (6.2-8.0 atü)
Weight:	1.20 kg
Box Quantity:	10 pcs

### OPT 700-A ORBIT SANDER



ORBIT SANDER	
Vibration:	< 2.5 mm
Orbit Diameter:	5 mm
Pad Diameter:	125-150 mm
Free Speed:	11.000 Rpm
Air Consumption:	180 l/min
Air Inlet:	1/4"
Hose Diameter:	10.00 mm
Working Pressure:	6.3-8 atü
Weight:	0.90 kg
Box Quantity:	6 pcs

### OPC 62403 ORBIT SANDER



ORBIT SANDER VACUUM	
Vibration:	< 2 mm
Orbit Diameter:	5 mm
Pad Diameter:	125-150 mm
Free Speed:	0-900 Rpm
Air Consumption:	151 l/min
Air Inlet:	1/4"
Hose Diameter:	10.00 mm
Working Pressure:	90-115 psi (6.2-8.0 atü)
Weight:	0.90 kg
Box Quantity:	6 pcs

### OPT 708 AIR GRATER



AIR GRATER	
Length:	410 mm
Pad Diameter:	63,6x400 mm
Free Speed:	3.000 Rpm
Air Consumption:	250 l/min
Air Inlet:	1/4"
Hose Diameter:	9.50 mm
Working Pressure:	90-115 psi (6.2-8.0 atü)
Weight:	2.60 kg
Box Quantity:	10 pcs

### OPC 65110-C FIBER SANDER



FIBER SANDER	
Length:	210 mm
Sander Diameter:	30x540 mm
Free Speed:	3.500 Rpm
Air Consumption:	255 l/min
Air Inlet:	1/4"
Hose Diameter:	10.00 mm
Working Pressure:	90-115 psi (6.2-8.0 atü)
Noise Level:	80 dB(A)
Weight:	1.20 kg

### OPT-P 800A ORBIT SANDER



75 MM SANDER	
Vibration:	< 2.5 mm
Pad Diameter:	75 mm
Orbit Diameter:	5 mm
Free Speed:	0-11.000 Rpm
Air Consumption:	151 U/min
Air Inlet:	1/4"
Hose Diameter:	11.00 mm
Working Pressure:	90-115 psi (6.2-8.0 atü)
Weight:	0.65 kg
Box Quantity:	10 pcs

### OPT 500A PALM SANDER



PALM SANDER	
Vibration:	< 2.5 mm
Pad Diameter:	100 mm
Orbit Diameter:	3.2 mm
Free Speed:	0-10.000 Rpm
Air Consumption:	150 U/min
Air Inlet:	1/4"
Hose Diameter:	10.00 mm
Working Pressure:	90-115 psi (6.2-8.0 atü)
Weight:	0.70 kg
Box Quantity:	10 pcs

### OPT 313 RECIPROCATING SAW



RECIPROCATING SAW	
Length:	235 mm
Cutting Capacity:	Steel 1.20 mm Sheet Metal 1.60 mm Aluminum 2.00 mm
Stroke:	10.0 mm
Stroke Frequency:	9.500 bpm
Air Consumption:	113 U/min
Air Inlet:	1/4"
Hose Diameter:	10 mm
Working Pressure:	90 psi (6.2 atü)
Weight:	0.54 kg
Box Quantity:	25 pcs

### OPT-P 319 RECIPROCATING SAW



RECIPROCATING SAW	
Length:	310 mm
Cutting Capacity:	Steel 1.60 mm Sheet Metal 2.00 mm Aluminum 3.26 mm
Stroke:	10.0 mm
Stroke Frequency:	9.500 bpm
Air Consumption:	170 U/min
Air Inlet:	1/4"
Hose Diameter:	10 mm
Working Pressure:	90 psi (6.2 atü)
Weight:	0.51 kg
Box Quantity:	10 pcs

### OPT-P 368 MINI ANGLE SANDER



MINI ANGLE SANDER	
Length:	148 mm
Pad Diameter:	50 mm
Free Speed:	15.000 Rpm
Air Consumption:	130 U/min
Air Inlet:	1/4"
Hose Diameter:	9.50 mm
Working Pressure:	90 psi (6.2 atü)
Weight:	0.70 kg
Box Quantity:	10 pcs

### OPT-P 716A MINI ANGLE SANDER



MINI ANGLE SANDER	
Length:	148 mm
Pad Diameter:	75 mm
Free Speed:	18.000 Rpm
Air Consumption:	130 U/min
Air Inlet:	1/4"
Hose Diameter:	9.50 mm
Working Pressure:	90 psi (6.2 atü)
Weight:	0.60 kg
Box Quantity:	10 pcs

### OPT-P 312C RECIPROCATING SAW



GEAR TYPE	
Length:	270 mm
Cutting Capacity:	Steel 1.70 mm Sheet Metal 2.10 mm Aluminum 3.35 mm
Stroke:	10.0 mm
Stroke Frequency:	5.000 bpm
Air Consumption:	210 U/min
Air Inlet:	1/4"
Hose Diameter:	10 mm
Working Pressure:	90 psi (6.2 atü)
Weight:	1.2 kg
Box Quantity:	10 pcs

### OPT-P 618 SPOT DRILL



SPOT DRILL	
Length:	210 mm
Bit Diameter:	8.0 mm
Free Speed:	500 Rpm
Air Consumption:	235 U/min
Air Inlet:	1/4"
Hose Diameter:	10 mm
Working Pressure:	90 psi (6.2 atü)
Weight:	1.60 kg
Box Quantity:	10 pcs

### OPT 706 PALM SANDER



PALM SANDER	
Length:	170 mm
Pad Diameter:	93x165 mm
Free Speed:	0-8.000 Rpm
Air Consumption:	90 U/min
Air Inlet:	1/4"
Hose Diameter:	9.50 mm
Working Pressure:	90-115 psi (6.2-8.0 atü)
Weight:	2.30 kg
Box Quantity:	10 pcs

### OPT-P 363 PALM SANDER



PALM SANDER	
Length:	230 mm
Pad Diameter:	110x220 mm
Free Speed:	0-6.000 Rpm
Air Consumption:	155 U/min
Air Inlet:	1/4"
Hose Diameter:	11.00 mm
Working Pressure:	90-115 psi (6.2-8.0 atü)
Weight:	2.20 kg
Box Quantity:	6 pcs

### OPT 673 PALM HAMMER



PALM HAMMER	
Stroke Frequency:	1.000 bpm
Working Pressure:	4-7 bar
Air Inlet:	1/4"
Weight:	0,90 kg
Box Quantity:	10 Pcs

### OPT-6126 PH PAH KIRMA MAKİNASI



AIR CHAMFERING TOOL	
Length:	140 mm
Capacity:	Mild Steel 0 - C2 Stainless Steel 0-C1, C2 Aluminum 3.35 mm
Free Speed:	3000 rpm
Air Consumption:	110 U/min
Noise Level:	80 Db (A)
Air Inlet:	1/4"
Hose Diameter:	10 mm
Working Pressure:	6.3 bar
Weight:	0.46 kg
Box Quantity:	10 pcs



### OPT 103R BLIND RIVET



BLIND RIVET	
Height:	290 mm
Rivet Diameter:	2.4-3.2-4-4.8 mm Aluminum
Stroke Capacity:	730 kg
Hose Diameter:	6.50 mm
Air Consumption:	40 l/min
Working Pressure:	90-115 psi (6.2-8.0 atü)
Weight:	1.50 kg
Box Quantity:	10 pcs

### OPT 103K BLIND RIVET



BLIND RIVET	
OPT 103R	1 pc
Service Kit	1 set
BMC Box	1 pc
Box Quantity	8 pcs

### OPT-P 5012 BLIND RIVET



BLIND RIVET	
Height:	273 mm
Rivet Diameter:	2.4-5 mm Aluminum 2.4-4 mm Steel
Stroke Capacity:	870 kg
Stroke:	14 mm
Air Consumption:	60 l/min
Air Inlet:	1/4"
Hose Diameter:	8.00 mm
Working Pressure:	90-115 psi (6.2-7.0 atü)
Weight:	1.40 kg
Box Quantity:	1 pc

### OPT-P 5020 BLIND RIVET



BLIND RIVET	
Height:	281 mm
Rivet Diameter:	2.4-5 mm Aluminum 2.4-5 mm Steel
Stroke Capacity:	1.800 kg
Stroke:	16 mm
Air Consumption:	80 l/min
Air Inlet:	1/4"
Hose Diameter:	8.00 mm
Working Pressure:	90-115 psi (6.2-7.0 atü)
Weight:	1.60 kg
Box Quantity:	1 pc

### OPT-P 4000R BLIND RIVET



BLIND RIVET	
Height:	288 mm
Rivet Diameter:	3.2-4-4.8 mm Steel
Stroke Capacity:	1.100 kg
Air Consumption:	40 l/min
Air Inlet:	1/4"
Hose Diameter:	8.00 mm
Hose Diameter:	9.50 mm
Working Pressure:	90-115 psi (6.2-8.0 atü)
Weight:	1.30 kg
Box Quantity:	6 pcs

### OPT-P 101 BLIND RIVET



BLIND RIVET	
Height:	190 mm
Rivet Diameter:	2.4-3.2-4-4.8 mm Steel
Stroke Capacity:	900 kg
Air Consumption:	80 l/min
Air Inlet:	1/4"
Hose Diameter:	8.00 mm
Hose Diameter:	9.50 mm
Working Pressure:	90-115 psi (6.2-8.0 atü)
Weight:	1.50 kg
Box Quantity:	10 pcs

### OPT-P 5040N BLIND RIVET



BLIND RIVET	
Height:	281 mm
Rivet Diameter:	4-4.8-6-6.4 mm Steel
Stroke:	14 mm
Stroke Capacity:	2.100 kg
Air Consumption:	80 l/min
Air Inlet:	1/4"
Hose Diameter:	8.00 mm
Working Pressure:	90-115 psi (6.2-7.0 atü)
Weight:	2.00 kg
Standard Accessories:	4-5-6-6.4 Collet
Box Quantity:	1 pc

### OPT-P 5060 I BLIND RIVET



MONOBOLT RIVET	
Height:	340 mm
Rivet Diameter:	8 mm Aluminum 4-4.8-6-6.4 Steel
Stroke:	26 mm
Stroke Capacity:	1.820 kg
Air Consumption:	90 l/min
Air Inlet:	1/4"
Hose Diameter:	8.00 mm
Working Pressure:	90-115 psi (6.2-7.0 atü)
Weight:	2.60 kg
Standard Acc.:	4-5-6-6.4 Collet
Box Quantity:	1 pc

### OPT-PS 6 RIVET NUT



RIVET NUT	
Height:	288 mm
Rivet Diameter:	3-4-5-6 mm
Standard Acc.:	M6
Stroke Capacity:	1.100 kg
Air Consumption:	240 l/min
Air Inlet:	1/4"
Hose Diameter:	8.00 mm
Working Pressure:	90-115 psi (6.2-8.0 atü)
Weight:	1.30 kg
Box Quantity:	6 pcs

### OSA-PS 6 SPARE JAWS



Unit Price for Each.	
Spare Jaws:	3-4-5-6 mm

### OPT-P 5075 LOCKBOLT BLIND RIVET



BLIND RIVET	
Height:	319 mm
Rivet Diameter SRB:	5-6.5 mm
BOM:	5 mm
Hucktainer:	10 mm
Stroke:	15 mm
Stroke Capacity:	2.200 kg
Air Consumption:	100 l/min
Air Inlet:	1/4"
Hose Diameter:	8.00 mm
Working Pressure:	90-115 psi (6.2-7.0 atü)
Weight:	2.20 kg
Box Quantity:	1 pc

**WARNING:**  
MAKE SURE THAT TENSILE STRENGTH  
OF THE USED RIVET IS LOWER THAN  
STROKE CAPACITY OF THE TOOL.



### OPT-P 5050 AS RIVET NUT



RIVET NUT	
Height:	292 mm
Rivet Diameter:	3-12 mm Steel
Stroke Capacity:	2.400 kg
Air Consumption:	90 l/min
Air Inlet:	1/4"
Hose Diameter:	8.00 mm
Working Pressure:	90-115 psi (6.2-7.0 atü)
Weight:	2.20 kg
Standard Acc.:	4-5-6-8-10 mm Nose Piece
Box Quantity:	1 pc

Stroke adjustment from head part, imbus bolt between M3-M5 can be used as nose piece

### OPT-P 5050 RIVET NUT



RIVET NUT	
Height:	292 mm
Rivet Diameter:	3-12 mm
Stroke Capacity:	2.400 kg
Hose Diameter:	8.00 mm
Air Inlet:	1/4"
Air Consumption:	90 l/min
Working Pressure:	90-115 psi (6.2-7.0 atü)
Weight:	2.20 kg
Standard Accessories:	4-5-6-8-10 mm Nose Piece
Optional:	3 ve 12 mm Nose Piece
Box Quantity:	1 pc

### OPT-P 50100 RIVET NUT



RIVET NUT	
Height:	306 mm
Rivet Diameter:	6-16 mm Steel
Stroke Capacity:	3.400 kg
Air Consumption:	90 l/min
Air Inlet:	1/4"
Hose Diameter:	8.00 mm
Working Pressure:	90-115 psi (6.2-7.0 atü)
Weight:	2.90 kg
Standard Acc.:	8-10-12 mm Nose Piece
Box Quantity:	1 pc

### IMBUS BOLT ADAPTER FOR OPT-P 5050 & OPT-P 5050AS

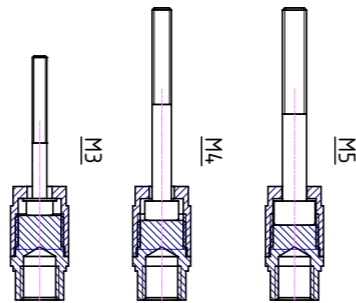

### OPT-P 5170R BATTERY BLIND RIVET



BLIND RIVET	
Rivet Diameter:	2,4-4,8 mm Steel
Stroke:	20mm
Stroke Capacity:	850 kg
Battery:	14,4 V/Li-ion
Charging Time:	60 min
Weight:	2.10 kg
Standard Accessories:	1 pc 14,4V Charger Unit
Box Quantity:	6 pcs

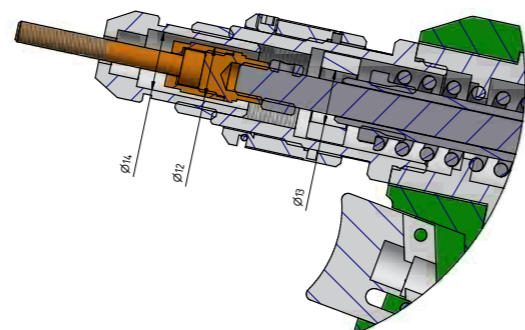



### OPT 150-6K CHIPPING HAMMER



CHIPPING HAMMER	
Length:	150 mm
Piston Diameter:	18.00 mm
Stroke:	43 mm
Blow per Minute:	4.600 bpm
Air Consumption:	150 l/min
Air Inlet:	1/4"
Hose Diameter:	10 mm
Working Pressure:	90-115 psi (6.2-8.0 atü)
Energy per Blow:	3.9 joule
Weight:	1.30 kg
Box Quantity:	10 pcs

### OPT 190-4K CHIPPING HAMMER



CHIPPING HAMMER	
Length:	190 mm
Piston Diameter:	21 mm
Stroke:	66 mm
Blow per Minute:	3.000 bpm
Air Consumption:	190 l/min
Air Inlet:	1/4"
Hose Diameter:	10 mm
Working Pressure:	90-115 psi (6.2-8.0 atü)
Energy per Blow:	8.7 joule
Weight:	2.30 kg
Box Quantity:	6 pcs

### OPT 281 NEEDLE SCALER



NEEDLE SCALER	
Length:	355 mm
Piston Diameter:	20 mm
Stroke:	43 mm
Blow per Minute:	4.500 bpm
Needle Diameter:	3x180 mm
Air Consumption:	250 l/min
Air Inlet:	1/4"
Hose Diameter:	10.00 mm
Working Pressure:	90-115 psi (6.2-8.0 atü)
Weight:	2.20 kg
Box Quantity:	10 pcs

### OPT-P 110 NEEDLE SCALER



NEEDLE SCALER	
Length:	252 mm
Piston Diameter:	20 mm
Stroke:	16 mm
Blow per Minute:	3.000 bpm
Needle Diameter:	3x180 mm
Air Consumption:	283 l/min
Air Inlet:	1/4"
Hose Diameter:	9.50 mm
Working Pressure:	90-115 psi (6.2-8.0 atü)
Weight:	2.60 kg
Box Quantity:	6 pcs

### OPT-P 180-5K CHIPPING HAMMER



CHIPPING HAMMER	
Length:	245 mm
Piston Diameter:	22 mm
Stroke:	92 mm
Blow per Minute:	2.700 bpm
Air Consumption:	580 l/min
Air Inlet:	1/4"
Hose Diameter:	10.00 mm
Working Pressure:	90 psi (6.2 atü)
Energy per Blow:	15.2 joule
Weight:	2.50 kg
Box Quantity:	10 pcs

### OPT-P 11 CHIPPING HAMMER



CHIPPING HAMMER	
Length:	245 mm
Rivet Diameter:	6 mm
Stroke:	45 mm
Blow per Minute:	3.000 bpm
Air Consumption:	550 l/min
Air Inlet:	1/4"
Hose Diameter:	11.00 mm
Working Pressure:	90-115 psi (6.2-8.0 atü)
Energy per Blow:	6.6 joule
Weight:	2.50 kg
Box Quantity:	2 pcs

### OPT-P 10 CHIPPING HAMMER



CHIPPING HAMMER	
Length:	175 mm
Piston Diameter:	19 mm
Stroke:	16 mm
Blow per Minute:	4.000 bpm
Needle Diameter:	3x125 mm
Air Consumption:	170 l/min
Air Inlet:	1/4"
Hose Diameter:	10 mm
Working Pressure:	90-115 psi (6.2-8.0 atü)
Weight:	1.20 kg
Box Quantity:	10 pcs

**OSA 10 NEEDLE SCALER  
OPTIONAL 95\$**

### OPT-P 20 CHIPPING HAMMER



CHIPPING HAMMER	
Length:	410 mm
Piston Diameter:	25 mm
Stroke:	22 mm
Blow per Minute:	4.000 bpm
Needle Diameter:	3x180 mm
Air Consumption:	300 l/min
Air Inlet:	1/4"
Hose Diameter:	11.00 mm
Working Pressure:	90-115 psi (6.2-8.0 atü)
Weight:	2.30 kg
Box Quantity:	10 pcs

**OSA 20 NEEDLE SCALER  
OPTIONAL 155\$**

### OPT-P 15 CHIPPING HAMMER



CHIPPING HAMMER	
Length:	425 mm
Rivet Diameter:	13 mm
Stroke:	102 mm
Blow per Minute:	1.500 bpm
Air Consumption:	600 l/min
Air Inlet:	3/8"
Hose Diameter:	13.00 mm
Working Pressure:	90-115 psi (6.2-8.0 atü)
Energy per Blow:	30.46 joule
Weight:	9.00 kg
Box Quantity:	2 pcs

### OPT-P 12 CHIPPING HAMMER



CHIPPING HAMMER	
Length:	380 mm
Rivet Diameter:	7.5 mm
Stroke:	51 mm
Blow per Minute:	2.500 bpm
Air Consumption:	600 l/min
Air Inlet:	3/8"
Hose Diameter:	13.00 mm
Working Pressure:	90-115 psi (6.2-8.0 atü)
Energy per Blow:	22.90 joule
Weight:	6.50 kg
Box Quantity:	2 pcs



## OPT-P 710-LK NEEDLE SCALER



NEEDLE SCALER	
Length:	710 mm
Piston Diameter:	16 mm
Stroke:	16 mm
Blow per Minute:	4.600 bpm
Needle Diameter:	3x125 mm
Air Consumption:	85 l/min
Air Inlet:	1/4"
Hose Diameter:	10 mm
Working Pressure:	90-115 psi (6.2-8.0 atü)
Weight:	2.60 kg
Box Quantity:	6 pcs

## OPT 923 SCALING HAMMER



SCALING HAMMER	
Length:	480 mm
Scaler Diameter:	15 mm
Blow per Minute:	7.200 bpm
Air Consumption:	85 l/min
Air Inlet:	1/4"
Hose Diameter:	10 mm
Working Pressure:	90-115 psi (6.2-8.0 atü)
Weight:	1.50 kg
Box Quantity:	6 pcs

## OPT 203 CAULKING GUN



CAULKING GUN	
Length:	310 mm
Air Inlet:	1/4"
Working Pressure:	90 psi (6.2 atü)
Weight:	0.40 kg
Box Quantity:	10 pcs

## OPT 2032-13 CAULKING GUN



CAULKING GUN	
Cartridge Size:	50x325 ml
Air Inlet:	1/4"
Working Pressure:	4-6 atü
Sausage:	400-500-600 ml
Box Quantity:	10 pcs

## OPT-P 220 MIXER



MIXER	
Length:	910 mm
Mixing Capacity:	20 lt
Piston:	3 pcs
Free Speed:	3600 Rpm
Air Consumption:	260 l/min
Air Inlet:	3/8"
Hose Diameter:	11 mm
Working Pressure:	90-115 psi (6.2-8.0 atü)
Weight:	5.50 kg
Box Quantity:	1 pc

## OPT-P 221 MIXER / BARREL TYPE



MIXER	
Length:	1110 mm
Mixing Capacity:	30 lt
Piston:	3 pcs
Free Speed:	630 Rpm
Air Consumption:	260 l/min
Air Inlet:	3/8"
Hose Diameter:	11 mm
Working Pressure:	(6.2-8.0 atü)
Weight:	10 kg
Box Quantity:	1 pc

## OPT-P 2034-13 CAULKING GUN



CAULKING GUN	
Cartridge Size:	50x325 ml
Air Inlet:	1/4"
Working Pressure:	4-6 atü
Sausage:	400-500-600 ml
Box Quantity:	10 pcs

## OPT 206 GREASE GUN



GREASE GUN	
Air Consumption:	60 lt
Air Inlet:	1/4"
Hose Diameter:	6 mm
Working Pressure:	6.3-8 atü
Weight:	0.45 kg
Box Quantity:	10 pcs

## OPT-P QS-2 AIR DENT PULLER



AIR DENT PULLER	
Sliding Hammer:	1.36 kg
Suction Pad:	2 pcs
Exhaust on Handle:	Yes
Air Inlet:	1/4"
Box Quantity:	4 pcs

## OPT 201 VACUUM



VACUUM	
Air Inlet:	1/4"
Box Quantity:	20 pcs

### OPT 3042 FR-L FRL UNIT 1/2"



FRL UNIT	
Air Inlet:	1/2"
Filtre:	20µ
Working Pressure:	0.5-9.9 atü
Working Temp.:	5-60°C
Tank Capacity:	80 ml
Air Flow Capacity:	2200 l/min
Box Quantity:	12 pcs

### OPT 2042 FR WATER FILTER 1/2"



WATER FILTER	
Air Inlet:	1/2"
Filtre:	20µ
Working Pressure:	0.5-9.9 atü
Working Temp.:	5-60°C
Tank Capacity:	80 ml
Air Flow Capacity:	2.200 l/min
Box Quantity:	12 pcs

### OPT-P 1000 WATER FILTER



WATER FILTER	
Length:	155 mm
Working Pressure:	1-70 kg/cm <sup>2</sup>
Air Flow Capacity:	300 l/min
Max. Pressure:	14 bar
Fluid Temperature:	5-60°C
Air Inlet:	1/4"
Air Outlet:	1/4"
Water Separation:	96%
Weight:	0.60 kg
Box Quantity:	20 pcs

### OPT-P 2000 WATER FILTER



WATER FILTER	
Length:	215 mm
Working Pressure:	1-70 kg/cm <sup>2</sup>
Air Flow Capacity:	400 l/min
Max. Pressure:	14 bar
Fluid Temperature:	5-60°C
Air Inlet:	1/2"
Air Outlet:	1/2"
Water Separation:	96%
Weight:	0.70 kg
Box Quantity:	20 pcs

### OPT 3012 FR-L FRL UNIT 1/4"



FRL UNIT	
Air Inlet:	1/4"
Filtre:	20µ
Working Pressure:	0.5-9.9 atü
Working Temp.:	5-60°C
Tank Capacity:	15 ml
Air Flow Capacity:	1.100 l/min
Box Quantity:	28 pcs

### OPT 2012 FR WATER FILTER 1/4"



WATER FILTER	
Air Inlet:	1/4"
Filtre:	20µ
Working Pressure:	0.5-9.9 atü
Working Temp.:	5-60°C
Tank Capacity:	15 ml
Air Flow Capacity:	1.100 l/min
Box Quantity:	30 pcs

### OPT-P 3000 WATER FILTER



WATER FILTER	
Length:	320 mm
Working Pressure:	1-70 kg/cm <sup>2</sup>
Air Flow Capacity:	800 l/min
Max. Pressure:	14 bar
Fluid Temperature:	5-60°C
Air Inlet:	3/4"
Air Outlet:	3/4"
Water Separation:	96%
Weight:	2.30 kg
Box Quantity:	6 pcs

### OPT 4042 FR-L FRL UNIT 1"



FRL UNIT	
Air Inlet:	1"
Filtre:	20µ
Working Pressure:	1-12 atü
Working Temp.:	5-60°C
Tank Capacity:	150 ml
Air Flow Capacity:	3.500 l/min
Box Quantity:	4 pcs



**OSAKA**<sup>®</sup> [www.osaka.com.tr](http://www.osaka.com.tr)

Hoses

## SPIRAL AIR HOSES - PU



Model No.	Int. x Ext. Diameter	Length	Box Q'ty
OPT05-25	5.0x8.0 mm	7.5 m	50
OPT05-50	5.0x8.0 mm	15 m	30
OPT06-25	6.5x10.0 mm	7.5 m	40
OPT06-50	6.5x10.0 mm	15 m	20
OPT08-25	8.0x12.0 mm	7.5 m	40
OPT08-50	8.0x12.0 mm	15 m	20
OPT11-25	11.0x16.0 mm	7.5 m	20
OPT11-50	11.0x16.0 mm	15 m	10

## OXYGEN ACETYLENE HOSES



Working Pressure 20 bar / Max. Pressue 60 bar		
OSA-H 0816	8 mm Oxygen Hose	100 m
OSA-H 1020	10 mm Oxygen Hose	100 m
OSA-H 2816	Double Hose 8 mm	50 m

## AIR ROLL HOSE - PU



Model No.	Material	Length	Color
2.5x4	PU Air Hose	200 m	Transparent-Blue-Orange
3x5	PU Air Hose	200 m	Transparent-Blue-Orange
4x6	PU Air Hose	200 m	Transparent-Blue-Orange
5x8	PU Air Hose	100 m	Transparent-Blue-Orange
6.5x10	PU Air Hose	100 m	Blue-Orange
8x12	PU Air Hose	100 m	Blue-Orange
11x16	PU Air Hose	100 m	Blue-Orange

## INDUSTRIAL PVC AIR HOSES



OPC 01812  
OPC 01140



OPC 00814  
OPC 01016  
OPC 01218  
OPC 01623

Model No.	Material	Size	Working Pressure	Color	Length	Standard
OPC 01812	PVC	8.0X12.0	6-12 BAR	TRANSPARENT	100 m	ISO-2398
OPC 01140	PVC	10.0X14.0	6-12 BAR	TRANSPARENT	100 m	ISO-2398
OPC 00814	PVC	8.0X14.0	6-20 BAR	BLACK	100 m	ISO-2398
OPC 01016	PVC	10.0X16.0	6-20 BAR	BLACK	100 m	ISO-2398
OPC 01218	PVC	12.5X18.5	6-20 BAR	BLACK	100 m	ISO-2398
OPC 01623	PVC	16.0X23.0	6-20 BAR	BLACK	50 m	ISO-2398

### OPT MH 100 AIR HOSE REEL



Auto Rewind	
Material	Hose: PU Body: Plastic
Hose Length:	12 m
Hose Diameter:	8x12 mm
Working Pressure:	10 bar
Lead Hose Length:	1 m

### OPT MH 150 AIR HOSE REEL



Auto Rewind	
Material	Hose: PU Body: Plastic
Hose Length:	12 m
Hose Diameter:	6.5x10 mm
Working Pressure:	10 bar
Lead Hose Length:	1 m

### OPT MK 165 AUTO CABLE REEL



Auto Rewind	
Cable Length:	12 m
Body:	Plastic
Cable:	3x1.5 mm
Cable Material:	Rubber
Socket:	230 V 50-60 Hz
Lead Cable Length:	1 m

### OPT MK 250 AUTO CABLE REEL



Auto Rewind	
Cable Length:	25 m
Body:	Plastic
Cable:	3x1.5 mm
Cable Material:	Rubber
Socket:	230 V 50-60 Hz
Lead Cable Length:	1 m

### OPT MH 200 AIR HOSE REEL



Auto Rewind	
Material	Hose: Woven PVC Body: Plastic
Hose Length:	20 m
Hose Diameter:	10x16 mm
Working Pressure:	10 bar
Lead Hose Length:	1 m

### OPT MH 230 AIR HOSE REEL



Auto Rewind	
Material	Hose: Woven PVC Body: Plastic
Hose Length:	20 m
Hose Diameter:	9,5x14 mm
Working Pressure:	10 bar
Lead Hose Length:	1 m

### OPT MS 14 WATER HOSE REEL



Auto Rewind	
Material	Hose: Woven PVC Body: Plastic
Hose Length:	14 m
Hose Diameter:	1/2"
Working Pressure:	6 bar
Lead Hose Length:	1 m

### OPT MS 20 WATER HOSE REEL



Auto Rewind	
Material	Hose: Woven PVC Body: Plastic
Hose Length:	20 m
Hose Diameter:	1/2"
Working Pressure:	6 bar
Lead Hose Length:	1 m

### OPT MH 210 AIR HOSE REEL



Auto Rewind	
Material	Hose: Woven PU Body: Metal
Hose Length:	20 m
Hose Diameter:	9.5x13.5 mm
Working Pressure:	18 bar
Lead Cable Length:	2 m
Size:	49x24x52 cm

### OPT MH 220 AIR HOSE REEL



Auto Rewind	
Material	Hose: Woven PU Body: Metal
Hose Length:	15 m
Hose Diameter:	12.7x17.5 mm
Working Pressure:	18 bar
Lead Cable Length:	2 m
Size:	49x24x52 cm

### OPT MS 28 WATER HOSE REEL



Auto Rewind	
Material	Hose: Woven PVC Body: Plastic
Hose Length:	28 m
Hose Diameter:	1/2"
Working Pressure:	6 bar
Lead Hose Length:	1 m



# TECNA®

Balancers



## TECNA BALANCER



PLASTIC BODY	
Model No.	Capacity / Length / Weight
9301	0.4-1 kg / 1600 mm / 0.6 kg
9302	1.0-2 kg / 1600 mm / 0.6 kg
9303	2.0-3 kg / 1600 mm / 0.7 kg



Model No.	Capacity / Length / Weight
9311	0.4-1 kg / 1600 mm / 0.6 kg
9312	1.0-2 kg / 1600 mm / 0.6 kg
9313	2.0-3 kg / 1600 mm / 0.7 kg



Model No.	Capacity / Length / Weight
9321	2.0-4 kg / 2000 mm / 2.0 kg
9322	4.0-6 kg / 2000 mm / 2.3 kg
9323	6.0-8 kg / 2000 mm / 2.5 kg



Model No.	Capacity / Length / Weight
9336	2-4 kg / 2500 mm / 3.0 kg
9339	8.0-10 kg / 2500 mm / 3.7 kg
9340	10.0-14 kg / 2500 mm / 4.0 kg

## TECNA BALANCER



Model No.	Capacity / Length / Weight
9357	14-18 kg / 2000 mm / 6.0 kg
9358	18-22 kg / 2000 mm / 6.5 kg
9359	22-25 kg / 2000 mm / 6.5 kg



Model No.	Capacity / Length / Weight
9362	15-20 kg / 2000 mm / 10.5 kg
9363	20-25 kg / 2000 mm / 11.0 kg
9364	25-30 kg / 2000 mm / 11.5 kg
9365	30-35 kg / 2000 mm / 11.8 kg
9366	35-45 kg / 2000 mm / 12.4 kg
9367	45-55 kg / 2000 mm / 12.5 kg
9368	55-65 kg / 2000 mm / 13.6 kg
9369	65-75 kg / 2000 mm / 14.5 kg



Model No.	Capacity / Length / Weight
9431	15-20 kg / 3000 mm / 19,1 kg
9432	20-25 kg / 3000 mm / 19,9 kg
9433	25-35 kg / 3000 mm / 20,9 kg



STOPLU	
Model No.	Capacity / Length / Weight
9346	2.0-4 kg / 2500 mm / 3.0 kg
9347	4.0-6 kg / 2500 mm / 3.3 kg
9348	6.0-8 kg / 2500 mm / 3.6 kg
9349	8.0-10 kg / 2500 mm / 3.8 kg
9350	10.0-14 kg / 2500 mm / 4.0 kg

## TECNA BALANCER

Model No.	Capacity / Length / Weight
9434	35-45 kg / 3000 mm / 23,8 kg
9435	40-50 kg / 3000 mm / 25,3 kg
9436	50-60 kg / 3000 mm / 25,0 kg
9441	60-70 kg / 3000 mm / 27,0 kg
9442	70-80 kg / 3000 mm / 27,0 kg
9444	80-100 kg / 3000 mm / 27,0 kg



Model No.	Capacity / Length / Weight
9403	30-40 kg / 2500 mm / 28 kg
9412	70-80 kg / 2500 mm / 35 kg
9422	100-120 kg / 2500 mm / 38,7 kg
9423	120-140 kg / 2500 mm / 41,9 kg
9425	140-160 kg / 2500 mm / 44,6 kg
9426	160-180 kg / 2500 mm / 49,0 kg
9451	100-115 kg / 3000 mm / 39,7 kg



Model No.	Capacity / Length / Weight
9200	0,40-80 kg / 1350 mm / 1,35 kg
9201	0,75-1,5 kg / 1350 mm / 1,35 kg
9202	1,2-2,5 kg / 1350 mm / 1,25 kg
9203	3-5 kg / 900 mm / 1,40 kg



Model No.	Capacity / Length / Weight
9370	75-90 kg / 2000 mm / 17,3 kg
9371	90-105 kg / 2000 mm / 18,0 kg

Model No.	Capacity / Length / Weight
OPT 15	0,6-1,5 kg / 1,5 mt
OPT 30	1,5-3 kg / 1,5 mt





**OSAKA**<sup>®</sup> [www.osaka.com.tr](http://www.osaka.com.tr)

Impact Sockets

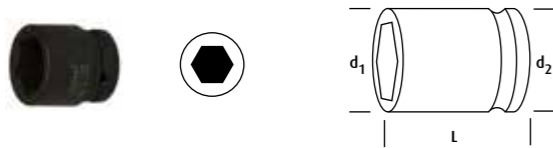

### IMPACT SOCKET 1/4"

Part No.	Size	Material	Tip Dia.	Inner Dia.	Outer Dia.	Length
LN14S04	1/4"	CR-MO	4 mm	7.7	13	25
LN14S045	1/4"	CR-MO	4.5 mm	8.3	13	25
LN14S05	1/4"	CR-MO	5 mm	9	13	25
LN14S055	1/4"	CR-MO	5.5 mm	9.6	13	25
LN14S06	1/4"	CR-MO	6 mm	10.2	13	25
LN14S07	1/4"	CR-MO	7 mm	11.5	13	25
LN14S08	1/4"	CR-MO	8 mm	12.8	13	25
LN14S09	1/4"	CR-MO	9 mm	14	13	25
LN14S10	1/4"	CR-MO	10 mm	14.5	13	25
LN14S11	1/4"	CR-MO	11 mm	16.6	13	25
LN14S12	1/4"	CR-MO	12 mm	17.7	13	25
LN14S13	1/4"	CR-MO	13 mm	19	13	25
LN14S14	1/4"	CR-MO	14 mm	20	13	25

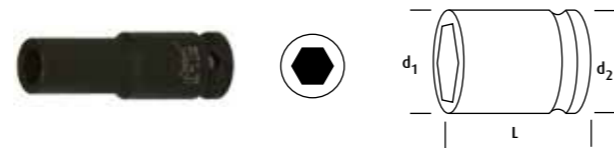

### DEEP IMPACT SOCKET 1/4"

Part No.	Size	Material	Tip Dia.	Inner Dia.	Outer Dia.	Length
LN14D04	1/4"	CR-MO	4 mm	7.7	13	50
LN14D045	1/4"	CR-MO	4.5 mm	8.3	13	50
LN14D05	1/4"	CR-MO	5 mm	9	13	50
LN14D055	1/4"	CR-MO	5.5 mm	9.6	13	50
LN14D06	1/4"	CR-MO	6 mm	10.2	13	50
LN14D07	1/4"	CR-MO	7 mm	10.3	13	50
LN14D08	1/4"	CR-MO	8 mm	11.5	13	50
LN14D09	1/4"	CR-MO	9 mm	12.8	13	50
LN14D10	1/4"	CR-MO	10 mm	14	13	50
LN14D11	1/4"	CR-MO	11 mm	14.5	13	50
LN14D12	1/4"	CR-MO	12 mm	16.6	13	50
LN14D13	1/4"	CR-MO	13 mm	17.7	13	50
LN14D14	1/4"	CR-MO	14 mm	19	13	50



### IMPACT SOCKET 3/8"

Part No.	Size	Material	Tip Dia.	Inner Dia.	Outer Dia.	Length
LN38S06	3/8"	CR-MO	6 mm	11	19	30
LN38S07	3/8"	CR-MO	7 mm	12.8	19	30
LN38S08	3/8"	CR-MO	8 mm	14	19	30
LN38S09	3/8"	CR-MO	9 mm	15.2	19	30
LN38S10	3/8"	CR-MO	10 mm	15.9	19	30
LN38S11	3/8"	CR-MO	11 mm	17.7	19	30
LN38S12	3/8"	CR-MO	12 mm	19	19	30
LN38S13	3/8"	CR-MO	13 mm	20.2	22	30
LN38S14	3/8"	CR-MO	14 mm	21.5	22	30
LN38S15	3/8"	CR-MO	15 mm	22.6	22	30
LN38S16	3/8"	CR-MO	16 mm	24	22	30
LN38S17	3/8"	CR-MO	17 mm	25.2	22	30
LN38S18	3/8"	CR-MO	18 mm	26.5	22	30
LN38S19	3/8"	CR-MO	19 mm	27.7	22	30
LN38S20	3/8"	CR-MO	20 mm	28.5	22	30
LN38S21	3/8"	CR-MO	21 mm	30	22	30
LN38S22	3/8"	CR-MO	22 mm	32	22	30



### STAR IMPACT SOCKET 3/8"

Part No.	Size	Material	Tip Dia.	Inner Dia.	Outer Dia.	Length
LN38Y06	3/8"	CR-MO	6 mm	11	19	30
LN38Y07	3/8"	CR-MO	7 mm	12.8	19	30
LN38Y08	3/8"	CR-MO	8 mm	14	19	30
LN38Y09	3/8"	CR-MO	9 mm	15.2	19	30
LN38Y10	3/8"	CR-MO	10 mm	15.9	19	30
LN38Y11	3/8"	CR-MO	11 mm	17.7	19	30
LN38Y12	3/8"	CR-MO	12 mm	19	19	30
LN38Y13	3/8"	CR-MO	13 mm	20.2	22	30
LN38Y14	3/8"	CR-MO	14 mm	21.5	22	30
LN38Y15	3/8"	CR-MO	15 mm	22.6	22	30
LN38Y16	3/8"	CR-MO	16 mm	24	22	30
LN38Y17	3/8"	CR-MO	17 mm	25.2	22	30
LN38Y18	3/8"	CR-MO	18 mm	26.5	22	30
LN38Y19	3/8"	CR-MO	19 mm	27.7	22	30
LN38Y20	3/8"	CR-MO	20 mm	28.5	22	30
LN38Y21	3/8"	CR-MO	21 mm	30	22	30
LN38Y22	3/8"	CR-MO	22 mm	32	22	30

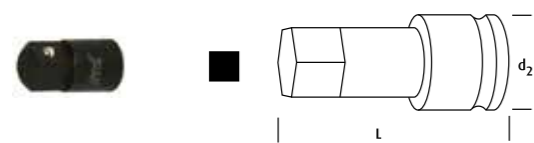

### ADAPTOR 1/4"

Part No.	Size	Material	Inner Dia.	Length
LN14-38AD	1/4"-3/8"	CR-MO	13.55	26.50

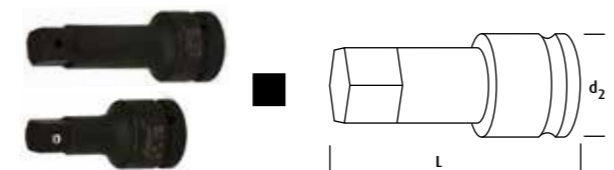

### EXTENSION 1/4"

Part No.	Size	Material	Length
LN14U050	1/4"	CR-MO	2"
LN14U075	1/4"	CR-MO	3"

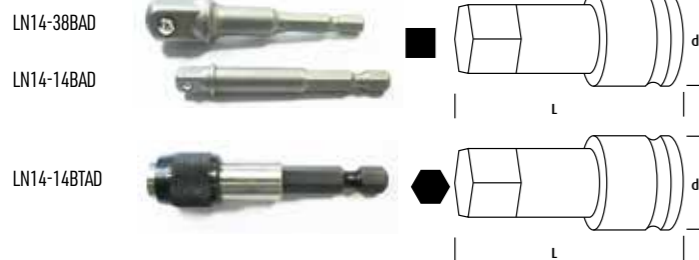

### ADAPTOR 1/4"

Part No.	Size	Material	Inner Dia.	Length
LN14-38BAD	3/8"	CR-MO		
LN14-14BAD	1/4"	CR-MO		
LN14-14BTAD	1/4"	CR-MO		75

### DEEP IMPACT SOCKET 3/8"

Part No.	Size	Material	Tip Dia.	Inner Dia.	Outer Dia.	Length
LN38D06	3/8"	CR-MO	6 mm	11	19	63
LN38D07	3/8"	CR-MO	7 mm	12.8	19	63
LN38D08	3/8"	CR-MO	8 mm	14	19	63
LN38D09	3/8"	CR-MO	9 mm	15.2	19	63
LN38D10	3/8"	CR-MO	10 mm	15.9	19	63
LN38D11	3/8"	CR-MO	11 mm	17.7	19	63
LN38D12	3/8"	CR-MO	12 mm	19	19	63
LN38D13	3/8"	CR-MO	13 mm	20.2	22	63
LN38D14	3/8"	CR-MO	14 mm	21.5	22	63
LN38D15	3/8"	CR-MO	15 mm	22.6	22	63
LN38D16	3/8"	CR-MO	16 mm	24	22	63
LN38D17	3/8"	CR-MO	17 mm	25.2	22	63
LN38D18	3/8"	CR-MO	18 mm	26.5	22	63
LN38D19	3/8"	CR-MO	19 mm	27.7	22	63
LN38D20	3/8"	CR-MO	20 mm	28.5	22	63
LN38D21	3/8"	CR-MO	21 mm	30	22	63
LN38D22	3/8"	CR-MO	22 mm	32	22	63



### STAR DEEP IMPACT SOCKET 3/8"

Part No.	Size	Material	Tip Dia.	Inner Dia.	Outer Dia.	Length
LN38YD06	3/8"	CR-MO	6 mm	11	19	63
LN38YD07	3/8"	CR-MO	7 mm	12.8	19	63
LN38YD08	3/8"	CR-MO	8 mm	14	19	63
LN38YD09	3/8"	CR-MO	9 mm	15.2	19	63
LN38YD10	3/8"	CR-MO	10 mm	15.9	19	63
LN38YD11	3/8"	CR-MO	11 mm	17.7	19	63
LN38YD12	3/8"	CR-MO	12 mm	19	19	63
LN38YD13	3/8"	CR-MO	13 mm	20.2	22	63
LN38YD14	3/8"	CR-MO	14 mm	21.5	22	63
LN38YD15	3/8"	CR-MO	15 mm	22.6	22	63
LN38YD16	3/8"	CR-MO	16 mm	24	22	63
LN38YD17	3/8"	CR-MO	17 mm	25.2	22	63
LN38YD18	3/8"	CR-MO	18 mm	26.5	22	63
LN38YD19	3/8"	CR-MO	19 mm	27.7	22	63
LN38YD20	3/8"	CR-MO	20 mm	28.5	22	63
LN38YD21	3/8"	CR-MO	21 mm	30	22	63
LN38YD22	3/8"	CR-MO	22 mm	32	22	63

### IMPULSE IMPACT SOCKET 3/8"

Part No.	Size	Material	Tip Dia.	Inner Dia.	Outer Dia.	Length
LN38P08	3/8"	CR-MO	8 mm	13	19	43
LN38P09	3/8"	CR-MO	9 mm	15	19	43
LN38P10	3/8"	CR-MO	10 mm	16	19	43
LN38P11	3/8"	CR-MO	11 mm	17.5	19	43
LN38P12	3/8"	CR-MO	12 mm	18.5	19	43
LN38P13	3/8"	CR-MO	13 mm	20	22	43
LN38P14	3/8"	CR-MO	14 mm	21	22	43
LN38P15	3/8"	CR-MO	15 mm	22	22	43
LN38P16	3/8"	CR-MO	16 mm	24	22	43
LN38P17	3/8"	CR-MO	17 mm	25	22	43
LN38P18	3/8"	CR-MO	18 mm	26	22	43
LN38P19	3/8"	CR-MO	19 mm	27	22	43

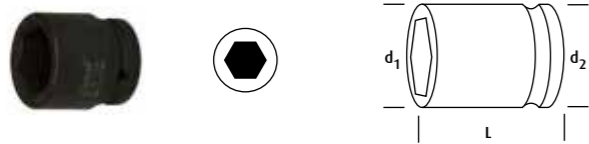

### INCH IMPACT SOCKET 3/8"

Part No.	Size	Material	Hex Size	d1	d2	L
LN38I1/4	3/8"	CR-MO	1/4	11	18	30
LN38I5/16	3/8"	CR-MO	5/16	12.5	18	30
LN38I3/8	3/8"	CR-MO	3/8	15	18	30
LN38I7/16	3/8"	CR-MO	7/16	17	18	30
LN38I1/2	3/8"	CR-MO	1/2	20	20	30
LN38I9/16	3/8"	CR-MO	9/16	22	22	30
LN38I5/8	3/8"	CR-MO	5/8	24	24	30
LN38I11/16	3/8"	CR-MO	11/16	26	26	30
LN38I3/4	3/8"	CR-MO	3/4	27	27	30
LN38I13/16	3/8"	CR-MO	13/16	30	30	30
LN38I7/8	3/8"	CR-MO	7/8	32	32	30

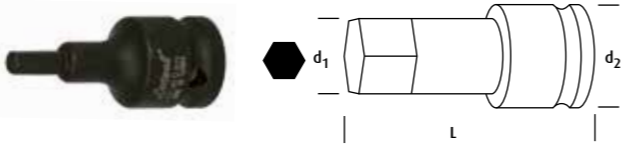

### ALLEN IMPACT SOCKET 3/8"

Part No.	Size	Material	Hex Size	d1	d2	L
LN38A03	3/8"	CR-MO	3 mm	6	25	50
LN38A04	3/8"	CR-MO	4 mm	6	25	50
LN38A05	3/8"	CR-MO	5 mm	6	25	50
LN38A06	3/8"	CR-MO	6 mm	11	25	50
LN38A08	3/8"	CR-MO	8 mm	11	25	50
LN38A10	3/8"	CR-MO	10 mm	11	25	50
LN38A12	3/8"	CR-MO	12 mm	14	25	50
LN38A14	3/8"	CR-MO	14 mm	16	25	50
LN38A16	3/8"	CR-MO	16 mm	20	25	50
LN38A17	3/8"	CR-MO	17 mm	20	25	50



### IMPACT SOCKET 1/2"

Part No.	Size	Material	Hex Size	d1	d2	L
LN12S08	1/2"	CR-MO	8 mm	15	24	38
LN12S09	1/2"	CR-MO	9 mm	16	24	38
LN12S10	1/2"	CR-MO	10 mm	17.5	24	38
LN12S11	1/2"	CR-MO	11 mm	18.5	24	38
LN12S12	1/2"	CR-MO	12 mm	19.5	24	38
LN12S13	1/2"	CR-MO	13 mm	20.5	24	38
LN12S14	1/2"	CR-MO	14 mm	22	24	38
LN12S15	1/2"	CR-MO	15 mm	24	24	38
LN12S16	1/2"	CR-MO	16 mm	24	24	38
LN12S17	1/2"	CR-MO	17 mm	26	26	38
LN12S18	1/2"	CR-MO	18 mm	28	28	38
LN12S19	1/2"	CR-MO	19 mm	28	30	38
LN12S20	1/2"	CR-MO	20 mm	30	30	38
LN12S21	1/2"	CR-MO	21 mm	30	30	38
LN12S22	1/2"	CR-MO	22 mm	32	30	38
LN12S23	1/2"	CR-MO	23 mm	34	30	38
LN12S24	1/2"	CR-MO	24 mm	34	30	38
LN12S25	1/2"	CR-MO	25 mm	36	30	38
LN12S26	1/2"	CR-MO	26 mm	36	30	38
LN12S27	1/2"	CR-MO	27 mm	38	30	38
LN12S28	1/2"	CR-MO	28 mm	40	30	42
LN12S29	1/2"	CR-MO	29 mm	42	30	42
LN12S30	1/2"	CR-MO	30 mm	42	30	42
LN12S32	1/2"	CR-MO	32 mm	44	30	42

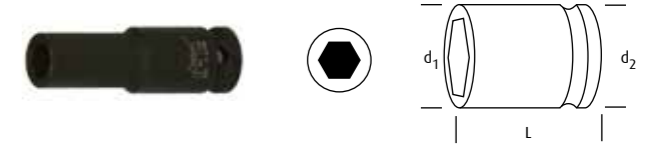

### DEEP IMPACT SOCKET 1/2"

Part No.	Size	Material	Hex Size	d1	d2	L
LN12D08	1/2"	CR-MO	8 mm	14	24	78
LN12D09	1/2"	CR-MO	9 mm	16	24	78
LN12D10	1/2"	CR-MO	10 mm	17.5	24	78
LN12D11	1/2"	CR-MO	11 mm	18.5	24	78
LN12D12	1/2"	CR-MO	12 mm	19.5	24	78
LN12D13	1/2"	CR-MO	13 mm	20.5	24	78
LN12D14	1/2"	CR-MO	14 mm	22	24	78
LN12D15	1/2"	CR-MO	15 mm	24	24	78
LN12D16	1/2"	CR-MO	16 mm	24	24	78
LN12D17	1/2"	CR-MO	17 mm	26	26	78
LN12D18	1/2"	CR-MO	18 mm	28	28	78
LN12D19	1/2"	CR-MO	19 mm	28	30	78
LN12D20	1/2"	CR-MO	20 mm	30	30	78
LN12D21	1/2"	CR-MO	21 mm	30	30	78
LN12D22	1/2"	CR-MO	22 mm	32	30	78
LN12D23	1/2"	CR-MO	23 mm	34	30	78
LN12D24	1/2"	CR-MO	24 mm	34	30	78
LN12D25	1/2"	CR-MO	25 mm	36	30	78
LN12D26	1/2"	CR-MO	26 mm	36	30	78
LN12D27	1/2"	CR-MO	27 mm	38	30	78
LN12D28	1/2"	CR-MO	28 mm	40	30	78
LN12D29	1/2"	CR-MO	29 mm	42	30	78
LN12D30	1/2"	CR-MO	30 mm	42	30	78
LN12D32	1/2"	CR-MO	32 mm	44	30	78

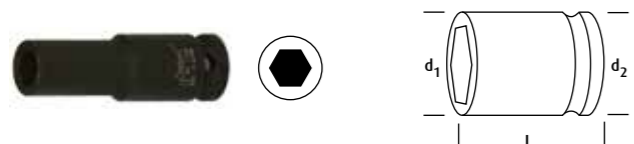

### INCH DEEP IMPACT SOCKET 3/8"

Part No.	Size	Material	Hex Size	d1	d2	L
LN38ID1/4	3/8"	CR-MO	1/4	11	18	63
LN38ID5/16	3/8"	CR-MO	5/16	12.5	18	63
LN38ID3/8	3/8"	CR-MO	3/8	15	18	63
LN38ID7/16	3/8"	CR-MO	7/16	17	18	63
LN38ID1/2	3/8"	CR-MO	1/2	20	20	63
LN38ID9/16	3/8"	CR-MO	9/16	22	22	63
LN38ID5/8	3/8"	CR-MO	5/8	24	24	63
LN38ID11/16	3/8"	CR-MO	11/16	26	26	63
LN38ID3/4	3/8"	CR-MO	3/4	27	27	63
LN38ID13/16	3/8"	CR-MO	13/16	30	30	63
LN38ID7/8	3/8"	CR-MO	7/8	32	32	63

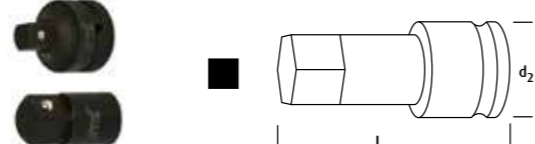

### ADAPTOR 3/8"

Part No.	Size	Material	d1	d2	L
LN12-38AD	1/2"-3/8"	CR-MO		25	36
LN14-38AD	1/4"-3/8"	CR-MO		13.55	26.5
LN38-14AD	3/8"-1/4"	CR-MO		25	36
LN38-12AD	3/8"-1/2"	CR-MO		30	38

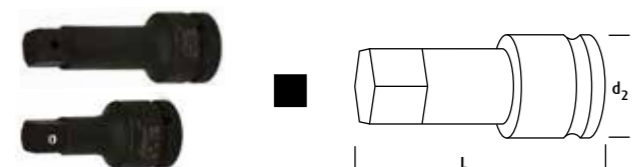

### EXTENSION 3/8"

Part No.	Size	Material	Hex Size	d1	d2	L
LN38U075	3/8"	CR-MO	3"		18	75
LN38U125	3/8"	CR-MO	5"		18	125
LN38U150	3/8"	CR-MO	6"		18	150

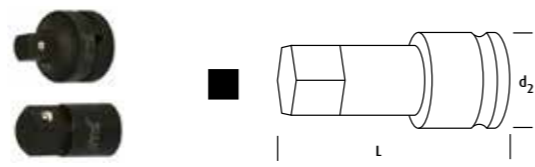

### UNIVERSAL JOINT 3/8"

Part No.	Size	Material	d1	d2	L
LN38M38	3/8"-3/8"	CR-MO		18	50

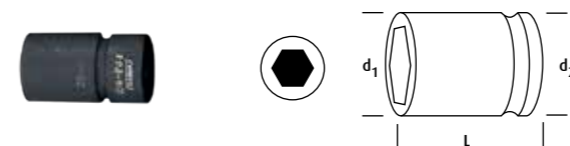

### IMPULSE IMPACT SOCKET 1/2"

Part No.	Size	Material	Hex Size	d1	d2	L
LN12P10	1/2"	CR-MO	10 mm	17.5	25	52
LN12P11	1/2"	CR-MO	11 mm	18.5	25	52
LN12P12	1/2"	CR-MO	12 mm	20	25	52
LN12P13	1/2"	CR-MO	13 mm	21	25	52
LN12P14	1/2"	CR-MO	14 mm	22.5	25	52
LN12P15	1/2"	CR-MO	15 mm	23.5	30	52
LN12P16	1/2"	CR-MO	16 mm	25	30	52
LN12P17	1/2"	CR-MO	17 mm	26	30	52
LN12P18	1/2"	CR-MO	18 mm	27.5	30	52
LN12P19	1/2"	CR-MO	19 mm	28.5	30	52
LN12P20	1/2"	CR-MO	20 mm	30	30	52
LN12P21	1/2"	CR-MO	21 mm	31	30	52
LN12P22	1/2"	CR-MO	22 mm	32	30	52



### SPECIAL FLIP SOCKET 18.5X19.5

Part No.	Size	Material	d1	d2	L
LN12C185	1/2"	CR-MO	26	28	78



### STAR IMPACT SOCKET 1/2"

Part No.	Size	Material	Tip Dia.	d1	d2	L
LN12Y08	1/2"	CR-MO	8 mm	15	38	38
LN12Y09	1/2"	CR-MO	9 mm	16	38	38
LN12Y10	1/2"	CR-MO	10 mm	17.5	38	38
LN12Y11	1/2"	CR-MO	11 mm	18.5	38	38
LN12Y12	1/2"	CR-MO	12 mm	19.5	38	38
LN12Y13	1/2"	CR-MO	13 mm	20.5	38	38
LN12Y14	1/2"	CR-MO	14 mm	22	38	38
LN12Y15	1/2"	CR-MO	15 mm	24	38	38
LN12Y16	1/2"	CR-MO	16 mm	24	38	38
LN12Y17	1/2"	CR-MO	17 mm	26	38	38
LN12Y18	1/2"	CR-MO	18 mm	28	38	38
LN12Y19	1/2"	CR-MO	19 mm	28	38	38
LN12Y20	1/2"	CR-MO	20 mm	30	38	38
LN12Y21	1/2"	CR-MO	21 mm	30	38	38
LN12Y22	1/2"	CR-MO	22 mm	32	38	38
LN12Y23	1/2"	CR-MO	23 mm	34	38	38
LN12Y24	1/2"	CR-MO	24 mm	34	38	38
LN12Y25	1/2"	CR-MO	25 mm	36	38	38
LN12Y26	1/2"	CR-MO	26 mm	36	38	38
LN12Y27	1/2"	CR-MO	27 mm	38	38	38
LN12Y28	1/2"	CR-MO	28 mm	40	42	42
LN12Y29	1/2"	CR-MO	29 mm	42	42	42
LN12Y30	1/2"	CR-MO	30 mm	42	42	42
LN12Y32	1/2"	CR-MO	32 mm	44	42	42



### INCH IMPACT SOCKET 1/2"

Part No.	Size	Material	Tip Dia.	d1	d2	L
LN12I5/16	1/2"	CR-MO	5/16	15	24	38
LN12I3/8	1/2"	CR-MO	3/8	16	24	38
LN12I7/16	1/2"	CR-MO	7/16	17	24	38
LN12I1/2	1/2"	CR-MO	1/2	18	24	38
LN12I9/16	1/2"	CR-MO	9/16	19	24	38
LN12I5/8	1/2"	CR-MO	5/8	24	24	38
LN12I11/16	1/2"	CR-MO	11/16	26	24	38
LN12I3/4	1/2"	CR-MO	3/4	28	24	38
LN12I13/16	1/2"	CR-MO	13/16	30	24	38
LN12I7/8	1/2"	CR-MO	7/8	32	24	38
LN12I15/16	1/2"	CR-MO	15/16	34	26	38
LN12I1-1/16	1/2"	CR-MO	1-1/16	38	26	38
LN12I1-1/8	1/2"	CR-MO	1-1/8	42	30	38
LN12I1-3/16	1/2"	CR-MO	1-3/16	42	30	38
LN12I1-1/4	1/2"	CR-MO	1-1/4	44	30	38

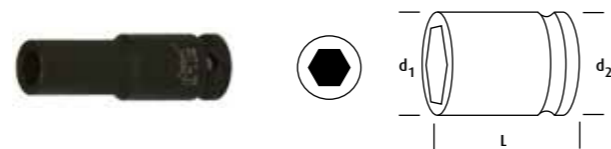

### INCH DEEP IMPACT SOCKET 1/2"

Part No.	Size	Material	Tip Dia.	d1	d2	L
LN12ID5/16	1/2"	CR-MO	5/16	15	24	78
LN12ID3/8	1/2"	CR-MO	3/8	16	24	78
LN12ID7/16	1/2"	CR-MO	7/16	17	24	78
LN12ID1/2	1/2"	CR-MO	1/2	18	24	78
LN12ID9/16	1/2"	CR-MO	9/16	19	24	78
LN12ID5/8	1/2"	CR-MO	5/8	24	24	78
LN12ID11/16	1/2"	CR-MO	11/16	26	24	78
LN12ID3/4	1/2"	CR-MO	3/4	28	24	78
LN12ID13/16	1/2"	CR-MO	13/16	30	24	78
LN12ID7/8	1/2"	CR-MO	7/8	32	24	78
LN12ID15/16	1/2"	CR-MO	15/16	34	26	78
LN12ID1-1/16	1/2"	CR-MO	1-1/16	38	26	78
LN12ID1-1/8	1/2"	CR-MO	1-1/8	42	30	78
LN12ID1-3/16	1/2"	CR-MO	1-3/16	42	30	78
LN12ID1-1/4	1/2"	CR-MO	1-1/4	44	30	78

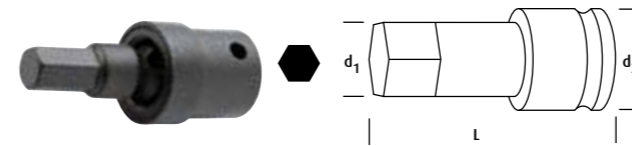

### UNIVERSAL JOINT ALLEN IMPACT SOCKET 1/2"

Part No.	Size	Material	Tip Dia.	d1	d2	L
LN12MA06	1/2"	CR-MO	6 mm	6	25	74
LN12MA07	1/2"	CR-MO	7 mm	6	25	74
LN12MA08	1/2"	CR-MO	8 mm	6	25	74
LN12MA10	1/2"	CR-MO	10 mm	11	25	74
LN12MA12	1/2"	CR-MO	12 mm	11	25	74
LN12MA14	1/2"	CR-MO	14 mm	11	25	74
LN12MA17	1/2"	CR-MO	17 mm	14	25	74
LN12MA19	1/2"	CR-MO	19 mm	16	25	74

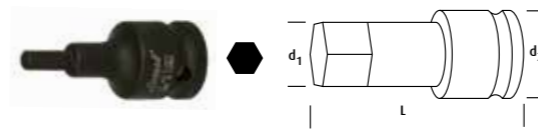

### ALLEN IMPACT SOCKET 1/2"

Part No.	Size	Material	Tip Dia.	d1	d2	L
LN12A04	1/2"	CR-MO	4 mm	6	25	60
LN12A05	1/2"	CR-MO	5 mm	6	25	60
LN12A06	1/2"	CR-MO	6 mm	11	25	60
LN12A08	1/2"	CR-MO	8 mm	11	25	60
LN12A10	1/2"	CR-MO	10 mm	11	25	60
LN12A12	1/2"	CR-MO	12 mm	14	25	60
LN12A14	1/2"	CR-MO	14 mm	16	25	60
LN12A17	1/2"	CR-MO	17 mm	18	25	60
LN12A19	1/2"	CR-MO	19 mm	20	25	60

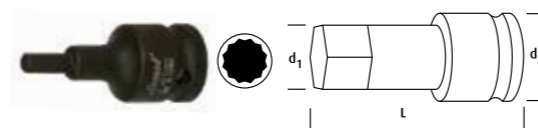

### STAR DEEP IMPACT SOCKET 1/2"

Part No.	Size	Material	Tip Dia.	d1	d2	L
LN12SA04	1/2"	CR-MO	4 mm	6	25	78
LN12SA05	1/2"	CR-MO	5 mm	6	25	78
LN12SA06	1/2"	CR-MO	6 mm	11	25	78
LN12SA08	1/2"	CR-MO	8 mm	11	25	78
LN12SA10	1/2"	CR-MO	10 mm	11	25	78
LN12SA12	1/2"	CR-MO	12 mm	14	25	78
LN12SA14	1/2"	CR-MO	14 mm	16	25	78
LN12SA16	1/2"	CR-MO	16 mm	18	25	78
LN12SA18	1/2"	CR-MO	18 mm	20	25	78

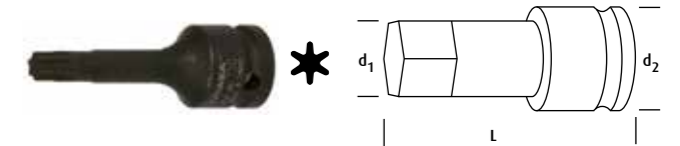

### TORX IMPACT SOCKET 1/2"

Part No.	Size	Material	Tip Dia.	d1	d2	L
LN12T20	1/2"	CR-MO	T20	10	25	78
LN12T25	1/2"	CR-MO	T25	10	25	78
LN12T27	1/2"	CR-MO	T27	10	25	78
LN12T30	1/2"	CR-MO	T30	10	25	78
LN12T35	1/2"	CR-MO	T35	10	25	78
LN12T40	1/2"	CR-MO	T40	10	25	78
LN12T45	1/2"	CR-MO	T45	10	25	78
LN12T50	1/2"	CR-MO	T50	10	25	78
LN12T55	1/2"	CR-MO	T55	11	25	78
LN12T60	1/2"	CR-MO	T60	12	25	78
LN12T80	1/2"	CR-MO	T80	12	25	78



### FEMALE TORX IMPACT SOCKET 1/2"

Part No.	Size	Material	Tip Dia.	d1	d2	L
LN12E10	1/2"	CR-MO	E10	13.5	25	38
LN12E12	1/2"	CR-MO	E12	15.5	25	38
LN12E14	1/2"	CR-MO	E14	17.5	25	38
LN12E16	1/2"	CR-MO	E16	19.6	25	38
LN12E18	1/2"	CR-MO	E18	21.8	25	38
LN12E20	1/2"	CR-MO	E20	23.8	25	38
LN12E22	1/2"	CR-MO	E22	25.8	25	38
LN12E24	1/2"	CR-MO	E24	28.3	25	38



### FEMALE TORX IMPACT SOCKET 3/4"

Part No.	Size	Material	Tip Dia.	d1	d2	L
LN34E22	3/4"	CR-MO	E22	36	44	57
LN34E24	3/4"	CR-MO	E24	38.8	44	57
LN34E26	3/4"	CR-MO	E26	41.3	44	57
LN34E28	3/4"	CR-MO	E28	44	44	57

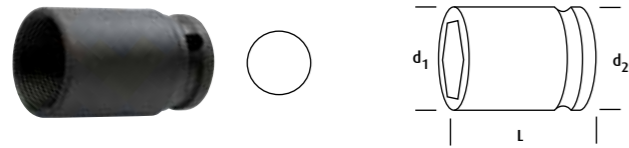

### LUGNUT REMOVER IMPACT SOCKET 1/2"

				d1	d2	L
LN12N17	1/2"	CR-MO	17 mm	23	25	55
LN12N185	1/2"	CR-MO	18.5 mm	25	25	55
LN12N20	1/2"	CR-MO	20 mm	26	25	55
LN12N215	1/2"	CR-MO	21.5 mm	28	30	55
LN12N23	1/2"	CR-MO	23 mm	30	30	55
LN12N245	1/2"	CR-MO	24.5 mm	30.5	30	55
LN12N26	1/2"	CR-MO	26 mm	32	30	55
LN12N275	1/2"	CR-MO	27.5 mm	33	30	55

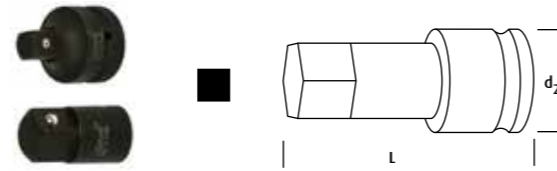

### ADAPTOR 1/2"

				d1	d2	L
LN12-38AD	1/2"-3/8"	CR-MO			25	38
LN12-34AD	1/2"-3/4"	CR-MO			30	48
LN38-12AD	3/8"-1/2"	CR-MO			30	48
LN34-12AD	3/4"-1/2"	CR-MO			44	58

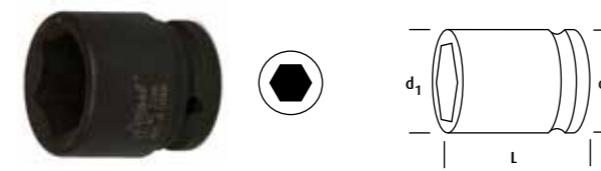

### IMPACT SOCKET 3/4"

				d1	d2	L
LN34S17	3/4"	CR-MO	17 mm	30.1	44	51
LN34S18	3/4"	CR-MO	18 mm	31.4	44	51
LN34S19	3/4"	CR-MO	19 mm	32.6	44	51
LN34S20	3/4"	CR-MO	20 mm	33.8	44	51
LN34S21	3/4"	CR-MO	21 mm	35.1	44	51
LN34S22	3/4"	CR-MO	22 mm	36.6	44	51
LN34S23	3/4"	CR-MO	23 mm	37.9	44	54
LN34S24	3/4"	CR-MO	24 mm	38.9	44	57
LN34S25	3/4"	CR-MO	25 mm	40.1	44	57
LN34S26	3/4"	CR-MO	26 mm	41.3	44	57
LN34S27	3/4"	CR-MO	27 mm	42.6	44	57
LN34S28	3/4"	CR-MO	28 mm	44	44	57
LN34S29	3/4"	CR-MO	29 mm	45.1	44	58
LN34S30	3/4"	CR-MO	30 mm	46.4	44	58
LN34S32	3/4"	CR-MO	32 mm	48.9	44	58
LN34S33	3/4"	CR-MO	33 mm	50.6	44	58
LN34S34	3/4"	CR-MO	34 mm	51.4	44	58
LN34S35	3/4"	CR-MO	35 mm	52.7	44	58
LN34S36	3/4"	CR-MO	36 mm	53.9	44	58
LN34S38	3/4"	CR-MO	38 mm	56.4	44	58
LN34S41	3/4"	CR-MO	41 mm	60.1	44	58
LN34S44	3/4"	CR-MO	44 mm	66.4	44	58
LN34S46	3/4"	CR-MO	46 mm	66.4	44	58
LN34S50	3/4"	CR-MO	50 mm	71.4	54	68
LN34S55	3/4"	CR-MO	55 mm	77.7	54	73
LN34S60	3/4"	CR-MO	60 mm	84.1	54	75
LN34S65	3/4"	CR-MO	65 mm	90.2	54	78
LN34S70	3/4"	CR-MO	70 mm	96.4	54	84

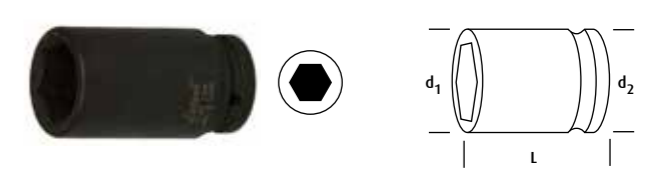

### DEEP IMPACT SOCKET 3/4"

				d1	d2	L
LN34D17	3/4"	CR-MO	17 mm	30.1	44	90
LN34D18	3/4"	CR-MO	18 mm	31.4	44	90
LN34D19	3/4"	CR-MO	19 mm	32.6	44	90
LN34D20	3/4"	CR-MO	20 mm	33.8	44	90
LN34D21	3/4"	CR-MO	21 mm	35.1	44	90
LN34D22	3/4"	CR-MO	22 mm	36.6	44	90
LN34D23	3/4"	CR-MO	23 mm	37.9	44	90
LN34D24	3/4"	CR-MO	24 mm	38.9	44	90
LN34D25	3/4"	CR-MO	25 mm	40.1	44	90
LN34D26	3/4"	CR-MO	26 mm	41.3	44	90
LN34D27	3/4"	CR-MO	27 mm	42.6	44	90
LN34D28	3/4"	CR-MO	28 mm	44	44	90
LN34D29	3/4"	CR-MO	29 mm	45.1	44	90
LN34D30	3/4"	CR-MO	30 mm	46.4	44	90
LN34D32	3/4"	CR-MO	32 mm	48.9	44	90
LN34D33	3/4"	CR-MO	33 mm	50.6	44	90
LN34D34	3/4"	CR-MO	34 mm	51.4	44	90
LN34D35	3/4"	CR-MO	35 mm	52.7	44	90
LN34D36	3/4"	CR-MO	36 mm	53.9	44	90
LN34D38	3/4"	CR-MO	38 mm	56.4	44	90
LN34D41	3/4"	CR-MO	41 mm	60.1	44	90
LN34D46	3/4"	CR-MO	46 mm	66.4	44	90
LN34D50	3/4"	CR-MO	50 mm	71.4	54	90
LN34D55	3/4"	CR-MO	55 mm	76.4	54	90

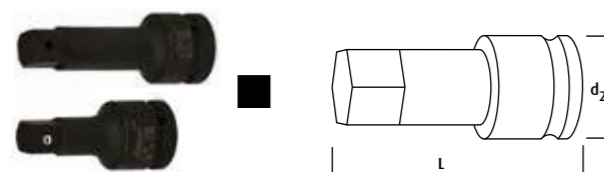

### EXTENSION 1/2"

				d1	d2	L
LN12U075	1/2"	CR-MO	3"		25	75
LN12U125	1/2"	CR-MO	5"		25	125
LN12U150	1/2"	CR-MO	6"		25	150

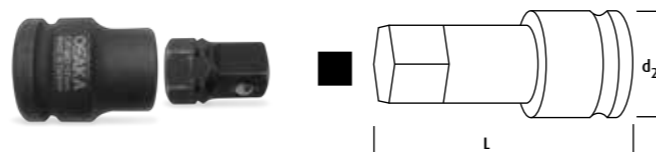

### INTERCHANGABLE ADAPTOR 1/2"

				d1	d2	L
LN34-12AG	3/4"-1/2"	CR-MO			25	38
LN34-12AGY	Yedek Uç	CR-MO			30	48

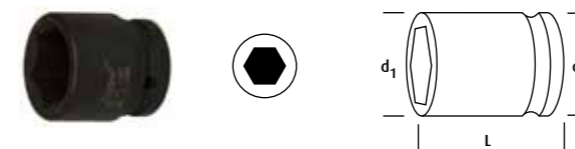

### INCH IMPACT SOCKET 3/4"

				d1	d2	L
LN34I11/16	3/4"	CR-MO	11/16	29	44	51
LN34I3/4	3/4"	CR-MO	3/4	32	44	51
LN34I3/16	3/4"	CR-MO	13/16	35	44	51
LN34I7/8	3/4"	CR-MO	7/8	36	44	51
LN34I5/16	3/4"	CR-MO	15/16	39	44	51
LN34I1	3/4"	CR-MO	1	41	44	54
LN34I1-1/16	3/4"	CR-MO	1-1/16	42	44	54
LN34I1-1/8	3/4"	CR-MO	1-1/8	44	44	54
LN34I1-3/16	3/4"	CR-MO	1-3/16	46	44	54
LN34I1-1/4	3/4"	CR-MO	1-1/4	48	44	57
LN34I1-5/16	3/4"	CR-MO	1-5/16	50	44	57
LN34I1-3/8	3/4"	CR-MO	1-3/8	44	44	54
LN34I1-1/2	3/4"	CR-MO	1-1/2	52	44	57
LN34I1-5/8	3/4"	CR-MO	1-5/8	56	44	57
LN34I1-13/16	3/4"	CR-MO	1-13/16	66	44	63
LN34I2-3/16	3/4"	CR-MO	2-3/16	78	54	73
LN34I2-3/8	3/4"	CR-MO	2-3/8	85	54	75
LN34I2-9/16	3/4"	CR-MO	2-9/16	86	54	75
LN34I2-3/4	3/4"	CR-MO	2-3/4	89	54	75

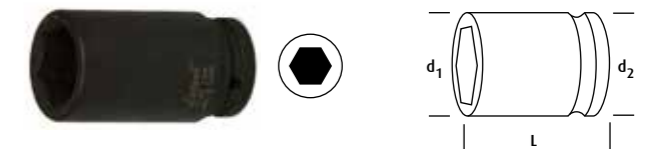

### INCH DEEP IMPACT SOCKET 3/4"

				d1	d2	L
LN34ID11/16	3/4"	CR-MO	11/16	29	44	90
LN34ID3/4	3/4"	CR-MO	3/4	32	44	90
LN34ID13/16	3/4"	CR-MO	13/16	35	44	90
LN34ID7/8	3/4"	CR-MO	7/8	36	44	90
LN34ID5/16	3/4"	CR-MO	15/16	39	44	90
LN34ID1	3/4"	CR-MO	1	41	44	90
LN34ID1-1/16	3/4"	CR-MO	1-1/16	42	44	90
LN34ID1-1/8	3/4"	CR-MO	1-1/8	44	44	90
LN34ID1-3/16	3/4"	CR-MO	1-3/16	46	44	90
LN34ID1-1/4	3/4"	CR-MO	1-1/4	48	44	90
LN34ID1-5/16	3/4"	CR-MO	1-5/16	50	44	90
LN34ID1-3/8	3/4"	CR-MO	1-3/8	44	44	90
LN34ID1-1/2	3/4"	CR-MO	1-1/2	52	44	90
LN34ID1-5/8	3/4"	CR-MO	1-5/8	56	44	90
LN34ID1-13/16	3/4"	CR-MO	1-13/16	66	44	90

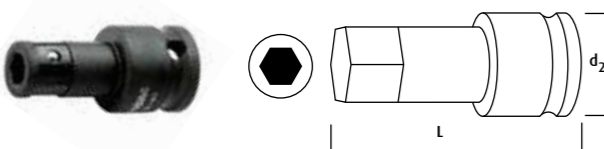

### BITS ADAPTOR 1/2" 1/4"

				d1	d2	L
LN12-14BAD	1/2"-1/4"	CR-MO			25	75

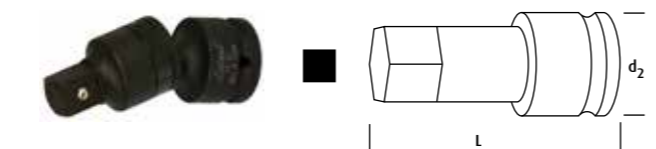

### UNIVERSAL JOINT 1/2"

				d1	d2	L
LN12M12	1/2"-1/2"	CR-MO			25	75

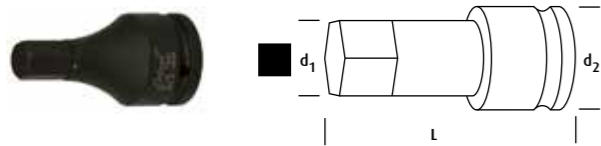

### ALLEN IMPACT SOCKET 3/4"

				d1	d2	L
LN34A14	3/4"	CR-MO	14 mm	20	44	100
LN34A17	3/4"	CR-MO	17 mm	22	44	100
LN34A19	3/4"	CR-MO	19 mm	22	44	100
LN34A21	3/4"	CR-MO	21 mm	25	44	100
LN34A22	3/4"	CR-MO	22 mm	25	44	100
LN34A24	3/4"	CR-MO	24 mm	28	44	100
LN34A27	3/4"	CR-MO	27 mm	32	44	100
LN34A30	3/4"	CR-MO	30 mm	35	44	100
LN34A32	3/4"	CR-MO	32 mm	36	44	100
LN34A36	3/4"	CR-MO	36 mm	36	44	100

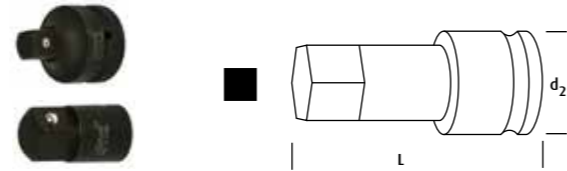

### ADAPTOR 3/4"

				d2	L
LN12-34AD	1/2"-3/4"	CR-MO		30	48
LN34-12AD	3/4"-1/2"	CR-MO		44	58
LN34-1AD	3/4"-1"	CR-MO		44	63
LN1-34AD	1"-3/4"	CR-MO		54	70

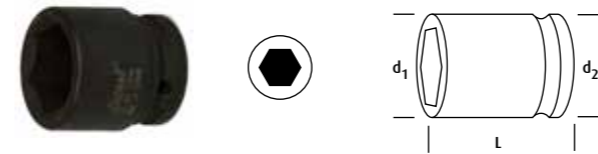

### IMPACT SOCKET 1"

				d1	d2	L
LN1S21	1"	CR-MO	21 mm	39.6	54	58
LN1S22	1"	CR-MO	22 mm	39.6	54	58
LN1S23	1"	CR-MO	23 mm	40.6	54	58
LN1S24	1"	CR-MO	24 mm	41.9	54	58
LN1S25	1"	CR-MO	25 mm	43.1	54	58
LN1S26	1"	CR-MO	26 mm	43.1	54	58
LN1S27	1"	CR-MO	27 mm	45.6	54	58
LN1S28	1"	CR-MO	28 mm	47	54	58
LN1S29	1"	CR-MO	29 mm	48.1	54	60
LN1S30	1"	CR-MO	30 mm	49.4	54	60
LN1S32	1"	CR-MO	32 mm	51.9	54	61
LN1S33	1"	CR-MO	33 mm	53.6	54	61
LN1S34	1"	CR-MO	34 mm	54.4	54	61
LN1S35	1"	CR-MO	35 mm	55.7	54	61
LN1S36	1"	CR-MO	36 mm	56.9	54	65
LN1S38	1"	CR-MO	38 mm	59.4	54	65
LN1S41	1"	CR-MO	41 mm	63.1	54	65
LN1S46	1"	CR-MO	46 mm	69.4	54	74
LN1S48	1"	CR-MO	48 mm	69.4	54	74
LN1S50	1"	CR-MO	50 mm	74.4	54	74
LN1S55	1"	CR-MO	55 mm	80.7	54	85
LN1S60	1"	CR-MO	60 mm	87.1	54	89
LN1S65	1"	CR-MO	65 mm	93.2	54	93
LN1S70	1"	CR-MO	70 mm	99.4	54	98
LN1S75	1"	CR-MO	75 mm	105.6	86	100
LN1S80	1"	CR-MO	80 mm	111.9	86	100
LN1S85	1"	CR-MO	85 mm	118.5	86	102
LN1S90	1"	CR-MO	90 mm	124.4	86	107
LN1S95	1"	CR-MO	95 mm	130.8	86	107
LN1S100	1"	CR-MO	100 mm	130.8	86	107

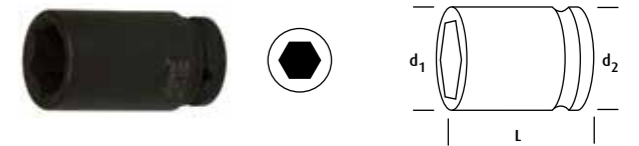

### DEEP IMPACT SOCKET 1"

				d1	d2	L
LN1D21	1"	CR-MO	21 mm	38	54	90
LN1D22	1"	CR-MO	22 mm	39.6	54	90
LN1D23	1"	CR-MO	23 mm	40.6	54	90
LN1D24	1"	CR-MO	24 mm	41.9	54	90
LN1D25	1"	CR-MO	25 mm	43.1	54	90
LN1D26	1"	CR-MO	26 mm	43.1	54	90
LN1D27	1"	CR-MO	27 mm	45.6	54	90
LN1D28	1"	CR-MO	28 mm	47	54	90
LN1D29	1"	CR-MO	29 mm	48.1	54	90
LN1D30	1"	CR-MO	30 mm	49.4	54	90
LN1D32	1"	CR-MO	32 mm	51.9	54	90
LN1D33	1"	CR-MO	33 mm	53.6	54	90
LN1D34	1"	CR-MO	34 mm	54.4	54	90
LN1D35	1"	CR-MO	35 mm	55.7	54	90
LN1D36	1"	CR-MO	36 mm	56.9	54	90
LN1D38	1"	CR-MO	38 mm	59.4	54	90
LN1D41	1"	CR-MO	41 mm	63.1	54	90
LN1D46	1"	CR-MO	46 mm	69.4	54	100
LN1D50	1"	CR-MO	50 mm	74.4	54	100
LN1D55	1"	CR-MO	55 mm	80.7	54	100
LN1D60	1"	CR-MO	60 mm	87.1	54	120
LN1D65	1"	CR-MO	65 mm	93.2	54	120
LN1D70	1"	CR-MO	70 mm	99.4	54	125
LN1D75	1"	CR-MO	75 mm	105.6	86	125
LN1D80	1"	CR-MO	80 mm	111.9	86	125
LN1D85	1"	CR-MO	85 mm	118.5	86	125
LN1D90	1"	CR-MO	90 mm	124.4	86	135

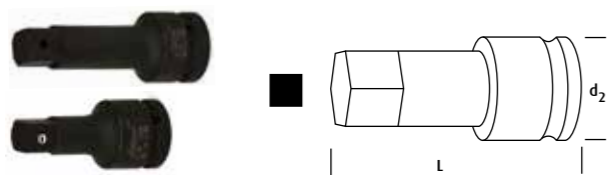

### EXTENSION 3/4"

				d1	d2	L
LN34U100	3/4"	CR-MO	4"		44	100
LN34U150	3/4"	CR-MO	6"		44	150
LN34U200	3/4"	CR-MO	8"		44	200
LN34U250	3/4"	CR-MO	10"		44	250

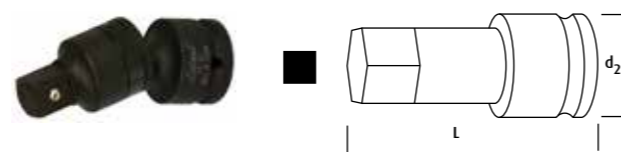

### UNIVERSAL JOINT 3/4"

				d2	L
LN34M34	3/4"-3/4"	CR-MO		44	105

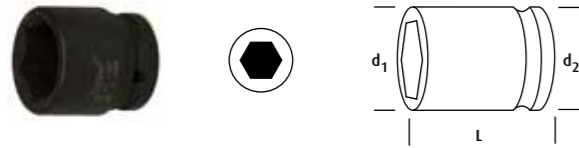

### INCH IMPACT SOCKET 1"

Part No.	Size	Material	Hex Size	d1	d2	L
LN111/16	1"	CR-MO	11/16	34	51	58
LN117/8	1"	CR-MO	7/8	39	54	58
LN115/16	1"	CR-MO	15/16	41	54	58
LN111	1"	CR-MO	1	42	54	58
LN111-1/16	1"	CR-MO	1-1/16	46	54	58
LN111-1/8	1"	CR-MO	1-1/8	46	54	58
LN111-3/16	1"	CR-MO	1-3/16	49	54	62
LN111-1/4	1"	CR-MO	1-1/4	52	54	62
LN111-5/16	1"	CR-MO	1-5/16	54	54	62
LN111-3/8	1"	CR-MO	1-3/8	54	54	62
LN111-7/16	1"	CR-MO	1-7/16	56	54	65
LN111-1/2	1"	CR-MO	1-1/2	58	54	65
LN111-9/16	1"	CR-MO	1-9/16	60	54	65
LN111-5/8	1"	CR-MO	1-5/8	61	54	68
LN111-11/16	1"	CR-MO	1-11/16	66	54	68
LN111-3/4	1"	CR-MO	1-3/4	67	54	68
LN111-13/16	1"	CR-MO	1-13/16	68	54	72
LN111-7/8	1"	CR-MO	1-7/8	68	54	72
LN111-15/16	1"	CR-MO	1-15/16	72	54	72
LN112	1"	CR-MO	2	74	54	75
LN112-1/16	1"	CR-MO	2-1/16	75	54	75
LN112-1/8	1"	CR-MO	2-1/8	78	54	80
LN112-3/16	1"	CR-MO	2-3/16	80	54	83
LN112-1/4	1"	CR-MO	2-1/4	82	54	83
LN112-5/16	1"	CR-MO	2-5/16	84	54	83
LN112-3/8	1"	CR-MO	2-3/8	86	54	87
LN112-7/16	1"	CR-MO	2-7/16	88	54	87
LN112-1/2	1"	CR-MO	2-1/2	90	54	87
LN112-9/16	1"	CR-MO	2-9/16	92	54	90
LN112-5/8	1"	CR-MO	2-5/8	94	54	90
LN112-11/16	1"	CR-MO	2-11/16	95	54	93
LN112-3/4	1"	CR-MO	2-3/4	96	54	93
LN112-13/16	1"	CR-MO	2-13/16	100	86	95
LN112-7/8	1"	CR-MO	2-7/8	102	86	95
LN112-15/16	1"	CR-MO	2-15/16	104	86	95
LN113	1"	CR-MO	3	106	86	95
LN113-1/16	1"	CR-MO	3-1/16	106	86	95
LN113-1/8	1"	CR-MO	3-1/8	109	86	95
LN113-1/4	1"	CR-MO	3-1/4	113	86	100
LN113-3/8	1"	CR-MO	3-3/8	115	86	100
LN113-1/2	1"	CR-MO	3-1/2	122	86	100
LN113-5/8	1"	CR-MO	3-5/8	127	86	100
LN113-3/4	1"	CR-MO	3-3/4	130	86	105
LN114	1"	CR-MO	4	132	86	105

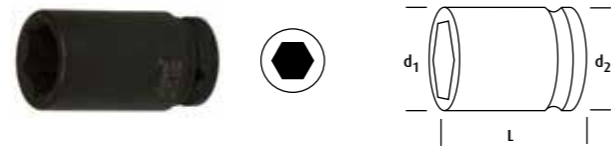

### INCH DEEP IMPACT SOCKET 1"

Part No.	Size	Material	Hex Size	d1	d2	L
LN1D7/8	1"	CR-MO	7/8	39	54	90
LN1D15/16	1"	CR-MO	15/16	41	54	90
LN1D1	1"	CR-MO	1	42	54	90
LN1D1-1/16	1"	CR-MO	1-1/16	46	54	90
LN1D1-1/8	1"	CR-MO	1-1/8	46	54	90
LN1D1-3/16	1"	CR-MO	1-3/16	49	54	90
LN1D1-1/4	1"	CR-MO	1-1/4	52	54	90
LN1D1-5/16	1"	CR-MO	1-5/16	54	54	90
LN1D1-3/8	1"	CR-MO	1-3/8	54	54	90
LN1D1-7/16	1"	CR-MO	1-7/16	56	54	90
LN1D1-1/2	1"	CR-MO	1-1/2	58	54	95
LN1D1-9/16	1"	CR-MO	1-9/16	60	54	95
LN1D1-5/8	1"	CR-MO	1-5/8	61	54	95
LN1D1-11/16	1"	CR-MO	1-11/16	66	54	95
LN1D1-3/4	1"	CR-MO	1-3/4	67	54	95
LN1D1-13/16	1"	CR-MO	1-13/16	68	54	95
LN1D1-7/8	1"	CR-MO	1-7/8	68	54	95
LN1D1-15/16	1"	CR-MO	1-15/16	72	54	100
LN1D2	1"	CR-MO	2	74	54	100
LN1D2-1/16	1"	CR-MO	2-1/16	75	54	100
LN1D2-1/8	1"	CR-MO	2-1/8	78	54	100
LN1D2-3/16	1"	CR-MO	2-3/16	80	54	105
LN1D2-1/4	1"	CR-MO	2-1/4	82	54	105
LN1D2-5/16	1"	CR-MO	2-5/16	84	54	105
LN1D2-3/8	1"	CR-MO	2-3/8	86	54	110
LN1D2-7/16	1"	CR-MO	2-7/16	88	54	110
LN1D2-1/2	1"	CR-MO	2-1/2	90	54	110
LN1D2-9/16	1"	CR-MO	2-9/16	92	54	115
LN1D2-5/8	1"	CR-MO	2-5/8	94	54	115
LN1D2-11/16	1"	CR-MO	2-11/16	95	54	120
LN1D2-3/4	1"	CR-MO	2-3/4	96	54	120
LN1D2-13/16	1"	CR-MO	2-13/16	100	86	135
LN1D2-7/8	1"	CR-MO	2-7/8	102	86	135
LN1D2-15/16	1"	CR-MO	2-15/16	104	86	135
LN1D3	1"	CR-MO	3	106	86	135
LN1D3-1/8	1"	CR-MO	3-1/8	109	86	135
LN1D3-1/4	1"	CR-MO	3-1/4	113	86	135
LN1D3-3/8	1"	CR-MO	3-3/8	115	86	140
LN1D3-1/2	1"	CR-MO	3-1/2	122	86	140

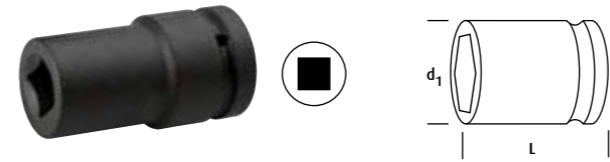

### SQUARE IMPACT SOCKET 1"

Part No.	Size	Material	Hex Size	d1	d2	L
LN1K17	1"	CR-MO	17 mm	40	54	58
LN1K19	1"	CR-MO	19 mm	42	54	58
LN1K20	1"	CR-MO	20 mm	44	54	58
LN1K21	1"	CR-MO	21 mm	44	54	58

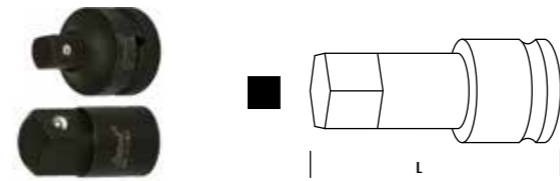

### ADAPTOR 1"

Part No.	Size	Material	d1	d2	L
LN34-1AD	3/4"-1"	CR-MO		44	63
LN1-34AD	1"-3/4"	CR-MO		54	70
LN1-15AD	1"-1.5"	CR-MO		54	90
LN15-1AD	1.5"-1"	CR-MO		86	100

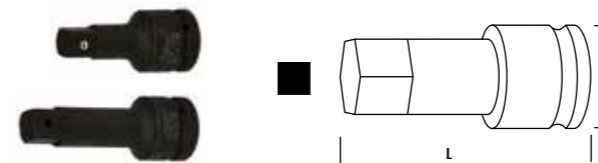

### EXTENSION 1"

Part No.	Size	Material	Hex Size	d1	d2	L
LN1U100	1"	CR-MO	4"		54	100
LN1U150	1"	CR-MO	6"		54	150
LN1U200	1"	CR-MO	8"		54	200
LN1U250	1"	CR-MO	10"		54	250
LN1U300	1"	CR-MO	12"		54	300

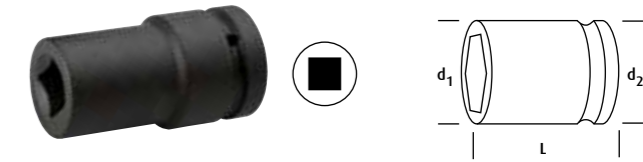

### SQUARE DEEP IMPACT WRENCH 1"

Part No.	Size	Material	Hex Size	d1	d2	L
LN1KD17	1"	CR-MO	17 mm	40	54	100
LN1KD19	1"	CR-MO	19 mm	42	54	100
LN1KD20	1"	CR-MO	20 mm	44	54	100
LN1KD21	1"	CR-MO	21 mm	44	54	100

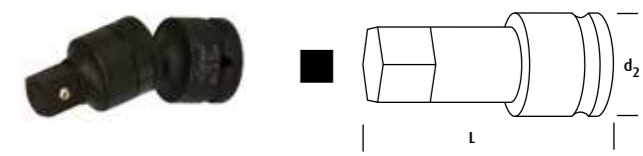

### UNIVERSAL JOINT 1"

Part No.	Size	Material	d1	d2	L
LN1M1	1"-1"	CR-MO		54	130

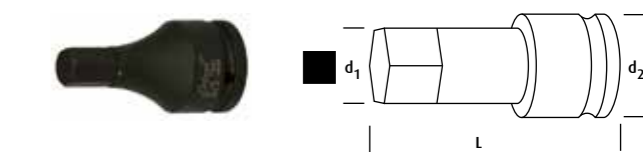

### ALLEN IMPACT SOCKET 1"

Part No.	Size	Material	Hex Size	d1	d2	L
LN1A14	1"	CR-MO	14 mm	20	44	100
LN1A17	1"	CR-MO	17 mm	20	44	100
LN1A19	1"	CR-MO	19 mm	22	44	100
LN1A21	1"	CR-MO	21 mm	25	44	100
LN1A22	1"	CR-MO	22 mm	25	44	100
LN1A24	1"	CR-MO	24 mm	28	44	100
LN1A27	1"	CR-MO	27 mm	32	44	100
LN1A30	1"	CR-MO	30 mm	35	44	100
LN1A32	1"	CR-MO	32 mm	36	44	100
LN1A36	1"	CR-MO	36 mm	36	44	100

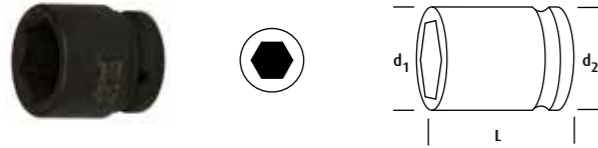

### IMPACT SOCKET 1.5"

				d1	d2	L
LN15S36	1.5"	CR-MO	36 mm	62	86	78
LN15S41	1.5"	CR-MO	41 mm	68	86	80
LN15S46	1.5"	CR-MO	46 mm	74	86	84
LN15S50	1.5"	CR-MO	50 mm	79	86	84
LN15S55	1.5"	CR-MO	55 mm	86	86	90
LN15S60	1.5"	CR-MO	60 mm	92	86	90
LN15S65	1.5"	CR-MO	65 mm	97	86	95
LN15S70	1.5"	CR-MO	70 mm	103	86	100
LN15S75	1.5"	CR-MO	75 mm	108	86	105
LN15S80	1.5"	CR-MO	80 mm	118	86	110
LN15S85	1.5"	CR-MO	85 mm	122	86	110
LN15S90	1.5"	CR-MO	90 mm	128	86	112
LN15S95	1.5"	CR-MO	95 mm	135	95	112
LN15S100	1.5"	CR-MO	100 mm	140	95	115
LN15S105	1.5"	CR-MO	105 mm	146	95	120
LN15S110	1.5"	CR-MO	110 mm	153	95	124
LN15S115	1.5"	CR-MO	115 mm	160	95	128
LN15S120	1.5"	CR-MO	120 mm	166	95	132
LN15S125	1.5"	CR-MO	125 mm	173	95	136
LN15S130	1.5"	CR-MO	130 mm	180	95	140

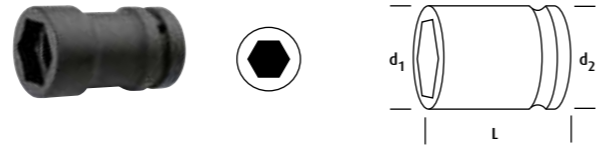

### DUAL OPENING BUDD WHEEL IMPACT SOCKET 1"

				d1	d2	L
LN1B3820	1"	CR-MO	38X20 mm	57	54	96
LN1B4121	1"	CR-MO	41X21 mm	58	54	100

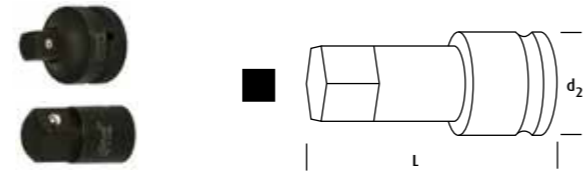

### ADAPTÖR LOKMA 1.5"

d1			d2	L
LN1-15AD	1" - 1.5"	CR-MO	54	90
LN15-1AD	1.5"-1"	CR-MO	86	100

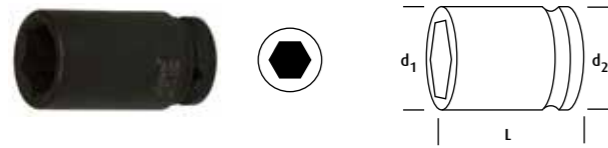

### DEEP IMPACT SOCKET 1.5"

				d1	d2	L
LN15D41	1.5"	CR-MO	41 mm	70	86	115
LN15D46	1.5"	CR-MO	46 mm	75	86	115
LN15D50	1.5"	CR-MO	50 mm	80	86	135
LN15D55	1.5"	CR-MO	55 mm	86	86	140
LN15D60	1.5"	CR-MO	60 mm	90	86	150





**LÜDECKE**

Quick Coupling

## ES SERIES QUICK COUPLING

AIR FLOW CAPACITY 1000 L/DK

ES QUICK COUPLING MALE			L	D
ES 14 A	R 1/4"	22	42	27
ES 38 A	R 3/8"	22	42	27
ES 12 AB	R 1/2"	22	42	27



ES QUICK COUPLING FEMALE			L	D
ES 14 I	R 1/4"	22	42	27
ES 38 I	R 3/8"	22	42	27
ES 12 I	R 1/2"	22	42	27



ES QUICK COUPLING HOSE			L	D
ES 8 T	8 mm	22	42	27
ES 10 T	9 mm	22	42	27
ES 13 T	13 mm	22	42	2



ES QUICK PLUG MALE			L	D
ES 14 NA	R 1/4"	17	33	9
ES 38 NA	R 3/8"	19	33	9
ES 12 NA	R 1/2"	24	35	9



ES QUICK PLUG FEMALE			L	D
ES 14 NI	R 1/4"	17	33	9
ES 38 NI	R 3/8"	19	33	9
ES 12 NI	R 1/2"	24	35	9



ES QUICK PLUG HOSE			L	D
ES 8 S	8 mm		44	12
ES 10 S	9 mm		44	12
ES 13 S	13 mm		44	12



## ESM SERIES QUICK COUPLING

AIR FLOW CAPACITY 510 L/DK

ESM QUICK COUPLING MALE			L	D
ESM 18 A	R 1/8"	14	37	7
ESM 14 A	R 1/4"	17	37	9



ESM QUICK COUPLING FEMALE			L	D
ESM 18 I	R 1/8"	14	37	9
ESM 14 I	R 1/4"	17	37	9



ESM QUICK COUPLING HOSE			L	D
ESM 6 T	6 mm		46	17
ESM 8 T	8 mm		46	17



ESM QUICK PLUG MALE			L	D
ESM 18 NA	R 1/8"	13	25	7
ESM 14 NA	R 1/4"	17	27,5	9



ESM QUICK PLUG FEMALE			L	D
ESM 18 NI	R 1/8"	13	25	9
ESM 14 NI	R 1/4"	17	26	10



ESM QUICK PLUG HOSE			L	D
ESM 6 S	6 mm		32	9
ESM 8 S	8 mm		32	12



ES DISTRIBUTOR			L	D
DWS 38 ES	R 3/8"	2'LI	67	26
VWS 38 ES	R 3/8"	3'LÜ	67	26



## ESG SERIES QUICK COUPLING

AIR FLOW CAPACITY 8000 L/DK

ESG QUICK COUPLING MALE			L	D
ESG 34 A	R 3/4"	41	95	46
ESG 10 A	R 1"	41	98	46



ESG QUICK COUPLING FEMALE			L	D
ESG 34 I	R 3/4"	41	99	46
ESG 10 I	R 1"	41	100	46



ESG QUICK COUPLING HOSE			L	D
ESG 19 T	19 mm		115	46
ESG 25 T	25 mm		125	46



ESG QUICK PLUG MALE			L	D
ESG 34 NA	R 3/4"	30	60	34
ESG 10 NA	R 1"	36	65	34



ESG QUICK PLUG FEMALE			L	D
ESG 34 NI	R 3/4"	32	58	34
ESG 10 NI	R 1"	41	68	34



ESG QUICK PLUG HOSE			L	D
ESG 19 S	19 mm		75	36
ESG 25 S	25 mm		87	48



## ESIG SERIES QUICK COUPLING

AIR FLOW CAPACITY 2150 L/DK

ESIG QUICK COUPLING MALE			L	D
ESIG 14 A	R 1/4"	24	63	27
ESIG 38 A	R 3/8"	24	63	27
ESIG 12 A	R 1/2"	24	65	27



ESIG QUICK COUPLING FEMALE			L	D
ESIG 14 I	R 1/4"	24	56	27
ESIG 38 I	R 3/8"	24	56	27
ESIG 12 I	R 1/2"	24	56	27



ESIG QUICK COUPLING HOSE			L	D
ESIG 13 T	13 mm	24	76	27
ESIG 16 T	16 mm	24	76	27
ESIG 19 T	19 mm	24	76	27



ESIG QUICK PLUG MALE			L	D
ESIG 14 NAS	R 1/4"	17	40	21
ESIG 38 NAS	R 3/8"	17	40	21
ESIG 12 NAS	R 1/2"	22	45	21



ESIG QUICK PLUG FEMALE			L	D
ESIG 14 NIS	R 1/4"	19	33	21
ESIG 38 NIS	R 3/8"	19	33	21
ESIG 12 NIS	R 1/2"	24	37	21



ESIG QUICK PLUG HOSE			L	D
ESIG 13 S	13 mm	24	76	27
ESIG 16 S	16 mm	24	76	27
ESIG 19 S	19 mm	24	76	27



### CLAW COUPLING

SKG HOSE CLAW COUPLING				
		L	D	
SKG 13	1/2"	13 mm	69	63
SKG 19	3/4"	19 mm	69	63
SKG 25	1"	25 mm	70	63
SKG 32	1 1/4"	32 mm	70	63



KIG FEMALE CLAW COUPLING				
		L	D	
KIG 12	1/2"	13 mm	38	63
KIG 34	3/4"	19 mm	40	63
KIG 10	1"	25 mm	40	63
KIG 54	1 1/4"	32 mm	55	63



KAG MALE CLAW COUPLING				
		L	D	
KAG 12	1/2"	13 mm	47	63
KAG 34	3/4"	19 mm	50	63
KAG 10	1"	25 mm	47	63
KAG 54	1 1/4"	32 mm	52	63



SKSS HOSE CLAW COUPLING				
		L	D	
SKSS 13	1/2"	13 mm	74	63
SKSS 19	3/4"	19 mm	75	63
SKSS 25	1"	25 mm	75	63



KISS FEMALE CLAW COUPLING				
		L	D	
KISS 12	1/2"	13 mm	37	63
KISS 34	3/4"	19 mm	39	63
KISS 10	1"	25 mm	47	63



KASS MALE CLAW COUPLING				
		L	D	
KASS 12	1/2"	13 mm	49	63
KASS 34	3/4"	19 mm	49	63
KASS 10	1"	25 mm	53	63



### MORTAR COUPLING AND HOSE CLAMP

MST HOSE MORTAR COUPLING				
		L	D	
MST 38		38 mm	77	132
MST 50		50 mm	94	140
MST 65		60 mm	105	185



MIG FEMALE MORTAR COUPLING				
		L	D	
MIG 15/42	1-1/2"	38 mm	84	66
MIG 20/50	2"	50 mm	94	79
MIG 25/65	2-1/2"	60 mm	105	81



VST HOSE MORTAR PLUG				
		L	D	
VST 38/35		38 mm	49.5	120
VST 50		50 mm	63	140
VST 65		65 mm	73	156



VAG MALE MORTAR PLUG				
		L	D	
VAG 10/25	1"	41	76	35
VAG 54/35	1-1/4"	50	83	49.5
VAG 25/42	1-1/2"	55	77	53
VAG 20/50	2"	65	90	63



SL HOSE CLAMP				
		L	D	
SL 29	22-29 mm	1/2"	18	63
SL 34	28-34 mm	3/4"	18	71
SL 40	32-40 mm	1"	18	81
SL 49	39-49 mm	1-1/4"	20	91
SL 60	48-60 mm	1-1/2"	24	108
SL 72	56-72 mm	2"	25	116
SL 76	60-76 mm	2-1/4"	25	127
SL 94	77-94 mm	2-1/2"	30	146



STOPER HORTUM GÖVDE	SIZE	NET WEIGHT	FLOW RATE	WORKING PRESSURE	MAX WORKING PRESSURE	BURSTING PRESSURE	WORKING TEMP.
OSA-GS 9T	9 mm	94,5 g	985 l/dk	6,3 bar	15 bar	55 bar	-25 ~ 50 °C
OSA-GS 11T	11 mm	96,9 g	1090 l/dk	6,3 bar	15 bar	55 bar	-25 ~ 50 °C



QUICK COUPLING MALE	SIZE	NET WEIGHT	FLOW RATE	WORKING PRESSURE	MAX WORKING PRESSURE	BURSTING PRESSURE	WORKING TEMP.
OSA-GS 14A	1/4"	92,2 g	1110 l/dk	6,3 bar	15 bar	55 bar	-25 ~ 50 °C
OSA-GS 38A	3/8"	95,9 g	1140 l/dk	6,3 bar	15 bar	55 bar	-25 ~ 50 °C
OSA-GS 12A	1/2"	106,65 g	1150 l/dk	6,3 bar	15 bar	55 bar	-25 ~ 50 °C



QUICK COUPLING FEMALE	SIZE	NET WEIGHT	FLOW RATE	WORKING PRESSURE	MAX WORKING PRESSURE	BURSTING PRESSURE	WORKING TEMP.
OSA-GS 14I	1/4"	107,6 g	1100 l/dk	6,3 bar	15 bar	55 bar	-25 ~ 50 °C
OSA-GS 38I	3/8"	98,6 g	1100 l/dk	6,3 bar	15 bar	55 bar	-25 ~ 50 °C
OSA-GS 12I	1/2"	105,25 g	1120 l/dk	6,3 bar	15 bar	55 bar	-25 ~ 50 °C





**OSA***access*

Accessories



### OSAKA FLAP DISC - ALUMINUM OXIDE

22.5 MM X 18 MM 72 PCS HIGH QUALITY SANDER

OSA-FLP115A0-120	115 mm Flap Disc Aluminum Oxide 120 Grit
------------------	--

### FILING MACHINE ACCESSORIES



### DIAMOND FILING SET

OSA EET09	12 Pcs Diamond Filing Set
-----------	---------------------------

### OPT-P 363 ACCESSORIES



### OSAKA HOOK AND LOOP SANDING SHEET

OSA-2251111	22.5 X 11 mm Hook and Loop Sanding Sheet
-------------	--

### OPT-P 368 ACCESSORIES



### OSAKA HOOK AND LOOP SANDING SHEET

22.5 MM X 18 MM 72 PCS HIGH QUALITY SANDER

OSA-0050	50 mm Hook and Loop Sanding Sheet
----------	-----------------------------------

### VACUUM ORBIT SANDER ACCESSORIES



### HOOK AND LOOK - STICK SANDING SHEETS

22.55 MM X 18 MM 72 PCS HIGH QUALITY SANDER

OSA-CZ125-60	125 mm 5 Holes, Hook and Loop Sanding Sheet 60 Grit
OSA-CZ125-80	125 mm 5 Holes, Hook and Loop Sanding Sheet 80 Grit
OSA-CZ125-120	125 mm 5 Holes, Hook and Loop Sanding Sheet 120 Grit
OSA-CZ125-150	125 mm 5 Holes, Hook and Loop Sanding Sheet 150 Grit
OSA-CZ125-180	125 mm 5 Holes, Hook and Loop Sanding Sheet 180 Grit

OSA-CZ150-60	150 mm 6+1 Holes, Hook and Loop Sanding Sheet 60 Grit
OSA-CZ150-80	150 mm 6+1 Holes, Hook and Loop Sanding Sheet 80 Grit
OSA-CZ150-100	150 mm 6+1 Holes, Hook and Loop Sanding Sheet 100 Grit
OSA-CZ150-120	150 mm 6+1 Holes, Hook and Loop Sanding Sheet 120 Grit
OSA-CZ150-150	150 mm 6+1 Holes, Hook and Loop Sanding Sheet 150 Grit
OSA-CZ150-180	150 mm 6+1 Holes, Hook and Loop Sanding Sheet 180 Grit
OSA-CZ150-220	150 mm 6+1 Holes, Hook and Loop Sanding Sheet 220 Grit

OSA-CZ125-60	125 mm 5 Holes, Hook and Loop Sanding Sheet
OSA-YZ125-80	125 mm 5 Holes, Stick Sanding Sheet 80 Grit
OSA-YZ125-120	125 mm 5 Holes, Stick Sanding Sheet 120 Grit
OSA-YZ125-150	125 mm 5 Holes, Stick Sanding Sheet 150 Grit

OSA-YZ150-60	150 mm 6 Holes, Stick Sanding Sheet 60 Grit
OSA-YZ150-80	150 mm 6 Holes, Stick Sanding Sheet 80 Grit
OSA-YZ150-120	150 mm 6 Holes, Stick Sanding Sheet 120 Grit
OSA-YZ150-150	150 mm 6 Holes, Stick Sanding Sheet 150 Grit

### SAW ACCESSORIES



### SPARE SAWS

OSA-YT313-18	Spare Daws 18 Tooth
OSA-YT313-32	Spare Daws 32 Tooth

### OPT-P 716 ACCESSORIES



### OSAKA THREADED SANDING SHEET

OSA-ZV375	37.5 mm Threaded 80-120-180-240-320 Grit
OSA-ZV500	50.0 mm Threaded 80-120-180-240-320 Grit
OSA-ZV750	75.0 mm Threaded 80-120-180-240-320 Grit

### OPT-P 716 ACCESSORIES



### OSAKA THREADED SCOTCH

OSA-ZS750	75 mm Threaded Scotch
-----------	-----------------------

### OPT-P 716 ACCESSORIES



### OSAKA CLICK-FIT SANDING SHEET

OSA-ZG375	37.5 mm Click-Fit 80-100-120 Grit
OSA-ZG500	50.0 mm Click-Fit 80-100-120 Grit
OSA-ZG750	75.0 mm Click-Fit 80-100-120 Grit

### OPT-P 100L ACCESSORIES



### OSAKA GRINDER ADAPTORS

100L-A01	Extension
100L-A02	Thick Wheel Adaptor



### SAND PAPER BELT

OSA-26060	260x60 mm Sand Paper Belt
-----------	---------------------------

### DIE GRINDER ACCESSORIES



### FIBER ABRASSIVE

OSA-PT157	37.5 mm Paint and Rust Cleaner
OSA-PT207	50.0 mm Paint and Rust Cleaner
OSA-PT307	75.0 mm Paint and Rust Cleaner
OSAPT-407	100.0 mm Paint and Rust Cleaner



### ORBIT SANDER ACCESSORIES

### SANDING PADS

OSA-C 2	50 mm Hook and Loop Pad
OSA-C 3	75 mm Hook and Loop Pad
OSA-C125	125 mm 5 Holes, Hook and Loop Pad
OSA-Y125	125 mm 5 Holes, Stick Pad
OSA-C150	150 mm 6 Holes, Hook and Loop Pad
OSA-Y150	150 mm 6 Holes, Stick Pad
OSA-C150 ND	150 mm No Holes, Stick Pad

### OPT-P 716A ACCESSORIES



### PLASTIC PADS

OSA-V154	37.5 mm Threaded Pad
OSA-V204	50.0 mm Threaded Pad
OSA-V304	75.0 mm Threaded Pad
OSA-G155	37.5 mm Click-Fit Pad
OSA-G205	50.0 mm Click-Fit Pad
OSA-G305	75.0 mm Click-Fit Pad

### BELT SANDER ACCESSORIES



### SAND PAPER BELT

OSA33010	330X100 mm Sander Paper Belt 80-100-120 Grit
OSA52020	520x20 mm Sander Paper Belt 80-100-120 Grit
OSA54030	540x30 mm Sander Paper Belt 80-100-120 Grit

### VACUUM SANDER ACCESSORIES



### HOOK AND LOOP PAD WITH HOLES

OSA-C150-54	Hook and Loop Pad with Holes
-------------	------------------------------

### 180 MM GRINDER ACCESSORIES



### PLASTIC HOOK AND LOOP PADS

OSA-PT704	150 mm Hook and Loop Pad M14
OSA-PT705	180 mm Hook and Loop Pad M14

### 125 MM & 180 MM GRINDER ACCESSORIES



### SANDING PADS

OSA-TC125	125 mm Hook and Loop Pad M14
OSA-TC150	150 mm Hook and Loop Pad M14



### POLISHING SPONGES

OSA-GSM14	14 mm Polishing Sponge White
OSA-PSM14	14 mm Polishing Sponge Yellow

## OPC 65110-C ACCESSORIES



OSA-065023 | 23 mm Brush



OSA 065801 | 23 mm Rubber Disc



OSA 065011 | 11 mm Brush



OSA 065701 | 11 mm Fiber Disc



OSA 065111 | 11 mm Stiff Brush



OSA 065903 | 11 mm Adaptor



OSA 065904 | 23 mm Adaptor



OSA 065123 | 23 mm Stiff Brush



OSA 065901 | 11 mm Scotch Adaptor



OSA 065902 | 23 mm Scotch Adaptor

## CHISELS AND SCALERS

### OPT-P 150-6K ACCESSORIES



OSA -KS2 | 4 pcs Chisel Set 125 mm

### OPT-P 150-6K ACCESSORIES



OSA -KS3 | 5 pcs Chisel Set 125 mm

### OPT-P 180-4K OPT-P 190-4K ACCESSORIES



OSA -KS4 | 5 pcs Chisel Set 175 mm



OSA -KS11-11 | Spare Point Chisel for OPT-P 11

OSA -KS12-11 | Spare Flat Chisel for OPT-P 11

OSA -KS11 | Spare Point Chisel for OPT-P 12 / OPT-P 15

OSA -KS12 | Spare Flat Chisel for OPT-P 12 / OPT-P 15



AH16 | Spring for OPT 150-6K

AH17 | Spring for OPT 190-4K



OSA -R10 | Needle Scaler for OPT-P 10



OSA -R20 | Needle Scaler for OPT-P 20

### OPT-P 281 ACCESSORIES



OSA-R1281 | 3x180 mm Needles for Needle Scaler



### CHISEL HOLDER

OSA-LKS5 | Automatic Chisel Holder

## SPARE CUTTERS FOR OPT 216



OSA-FK02 Spare Cutter



OSA-FK03 Spare Cutter



OSA-FK07 Spare Cutter



OSA-FK04 Spare Cutter Length 9 cm



OSA-FK01 Spare Cutter



## TAPPING MACHINE ADAPTOR

OSA-TCS2-TCS1 Adaptor



## TAPPING MACHINE SPARE CHUCKS

### 3-12

OSA-KTP2/TCS1	Spare Chuck
OSA-KTP3/TCS1	Spare Chuck
OSA-KTP4/TCS1	Spare Chuck
OSA-KTP5/TCS1	Spare Chuck
OSA-KTP6/TCS1	Spare Chuck
OSA-KTP8/TCS1	Spare Chuck
OSA-KTP10/TCS1	Spare Chuck
OSA-KTP12/TCS1	Spare Chuck

### 3-16 / 4-22

OSA-KTP4/TCS2	Spare Chuck
OSA-KTP5/TCS2	Spare Chuck
OSA-KTP6/TCS2	Spare Chuck
OSA-KTP8/TCS2	Spare Chuck
OSA-KTP10/TCS2	Spare Chuck
OSA-KTP12/TCS2	Spare Chuck
OSA-KTP 14/TCS2	Spare Chuck
OSA-KTP16/TCS2	Spare Chuck
OSA-KTP18/TCS2	Spare Chuck
OSA-KTP20/TCS2	Spare Chuck
OSA-KTP22/TCS2	Spare Chuck



## MINI GREASE PUMP

OSA-MG P1035 Mini Grease Pump



## SWIVEL FITTINGS

OSA-1012	Swivel Fitting
OSA-1014	Swivel Fitting 1/4" - 1098 l/min at 6 bar
OSA-1015	Swivel Fitting 3/8" - 1098 l/min at 6 bar



## MINI REGULATOR

OSA-1010 Mini Regulator



## MINI WATER FILTER

OSA-1026 Mini Water Filter



## MINI LUBRICATOR

OSA-1025 Mini Lubricator



## MINI REGULATOR WITH GAUGE

OSA-1013 Mini Regulator with Gauge



### OPT-P 619 ACCESSORIES



#### SPOT DRILL BIT

OSA-619	8.00 mm Carbide Spot Drill Bit
---------	--------------------------------

### DIE GRINDER ACCESSORIES



#### SPARE COLLET

OSA-P3	3 mm Collet
OSA-P6	6 mm Collet



Box Quantity 2 pcs

#### HOOK AND LOOP POLISHING SPONGES

OSA-SNG150S	150 mm Soft
OSA-SNG180S	180 mm Soft
OSA-SNG200S	200 mm Soft



Box Quantity 2 pcs

#### HOOK AND LOOP POLISHING SPONGE

OSA-SNG150H	150 mm Firm
OSA-SNG180H	180 mm Firm
OSA-SNG200H	200 mm Firm



#### SPADE DIAMOND BITS

OSA-Y940	Spare Diamond Bits for OPT-P 940
----------	----------------------------------



#### OPT-P 5050 SPINDLES

OSA-5050 3	Spare Spindle M3
OSA-5050 4	Spare Spindle M4
OSA-5050 5	Spare Spindle M5
OSA-5050 6	Spare Spindle M6
OSA-5050 8	Spare Spindle M8
OSA-5050 10	Spare Spindle M10
OSA-5050 12	Spare Spindle M12



#### HOOK AND LOOP POLISHING PADS

OSA-PLS50	180 mm Wool Polishing Pad
OSA-PLS70	200 mm Wool Polishing Pad



#### CIRTLI POLİSAJ PEDİ

OSA-PLS125	125 mm Wool Polishing Pad
OSA-PLS150	150 mm Wool Polishing Pad
OSA-PLS180	180 mm Wool Polishing Pad
OSA-PLS300	200 mm Wool Polishing Pad



#### SPARE CUTTERS

OSA-FD6	Plastic Cutter for OPT 1007
OSA-PC2	Clamp Piler 10.7 mm for OPT 1008 / OPT 1009
OSA-PC4	Clamp Piler 13 mm for OPT 1008 / OPT 1009
OSA-AR7WP	Cable Terminal Cripser 2mm - 5.5 mm for OPT 1008



#### QUICK CHANGE ADAPTER

OSA06011	M14 Quick Change Adapter
----------	--------------------------



**OSAFix**

Rivets

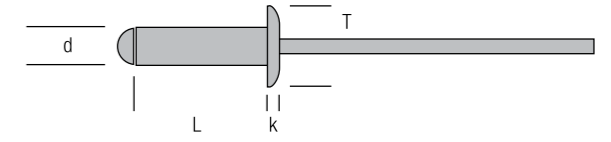
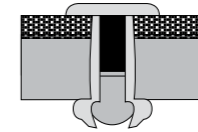
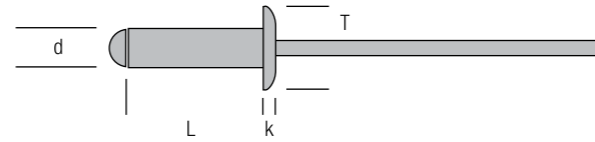
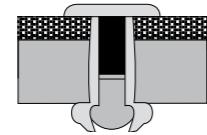

### STEEL-STEEL DOMED HEAD BLIND RIVET

d	L	T	K	N		Pack Q'ty	Weight	Model No.	
mm	mm	mm	mm	mm	N	N	Pcs	Kg	
3.2	14.0	6.5	0.80	9.0-11.0	1100	1300	1000	1.92	OSF-CPP 3214
4.0	6.0	8.0	1.0	2.0-4.0	1800	2500	1000	2.45	OSF-CPP 4006
	8.0			2.0-4.0			1000	2.45	OSF-CPP 4008
	10.0			4.0-6.0			1000	2.47	OSF-CPP 4010
	12.0			6.0-8.0			1000	2.69	OSF-CPP 4012
	14.0			8.0-10.0			1000	3.01	OSF-CPP 4014
	16.0			10.0-12.0			1000	2.22	OSF-CPP 4016
	18.0			12.0-14.0			500	1.30	OSF-CPP 4018
	20.0			14.0-16.0			500	1.90	OSF-CPP 4020
4.8	8.0	9.5	1.1	1.0-3.0	3000	4000	500	1.78	OSF-CPP 4808
	10.0			3.0-5.0			500	1.91	OSF-CPP 4810
	12.0			5.0-7.0			500	2.14	OSF-CPP 4812
	14.0			7.0-9.0			500	2.19	OSF-CPP 4814
	16.0			9.0-11.0			500	2.22	OSF-CPP 4816
6.0	12.0	32 mm	32 mm	4.0-7.0	3500	5700	500	2.05	OSF-CPP 6012
	14.0			7.0-10.0			500	2.20	OSF-CPP 6014
6.4	12.0	13.4	1.8	4.0-7.0	4000	6200	250	2.14	OSF-CPP 6412
	14.0			7.0-10.0			250	2.37	OSF-CPP 6414
	16.0			14.0-17.0			250	2.41	OSF-CPP 6416
	18.0			10.0-13.0			250	2.72	OSF-CPP 6418
	20.0			13.0-19.0			250	2.94	OSF-CPP 6420
	25.0			16.0-21.0			250	3.04	OSF-CPP 6425
	30.0			20.0-25.0			250	3.45	OSF-CPP 6430

### STEEL-STEEL CUPLOCK BLIND RIVET

d	L	T	K	N		Pack Q'ty	Weight	Model No.	
mm	mm	mm	mm	mm	N	N	Pcs	Kg	
3.2	10.5	6.5	0.80	5.0-7.0	4200	6500	1000	1.95	OSF-CUP 4810
	14.5			8.0-10.0			1000	2.20	OSF-CUP 4814
6.4	14.5			7.0-10.0	6700	8400	1000	2.70	OSF-CUP 6414
	20.5			13.0-19.0			1000	3.20	OSF-CUP 6420

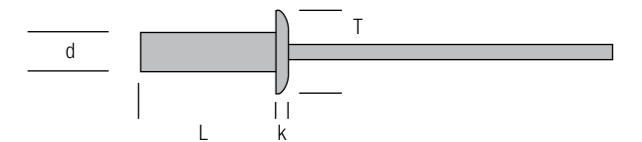
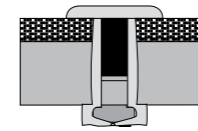

### ALUMINUM-STEEL SEALING BLIND RIVET

d	L	T	K	N		Pack Q'ty	Weight	Model No.	
mm	mm	mm	mm	mm	N	N	Pcs	Kg	
4.8	6.0			1.0-3.0			1000		OSF-KPA 4806
	8.0			2.0-4.0			1000		OSF-KPA 4808
	10.0			3.0-5.0			1000		OSF-KPA 4810
	12.0			5.0-7.0			1000		OSF-KPA 4812

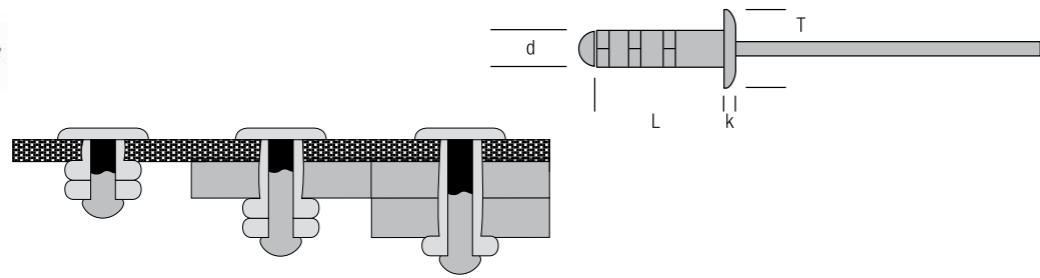

MULTI GRIP BLIND RIVET									
d	L	T	K	mm		Pack Q'ty	Weight	Model No.	
mm	mm	mm	mm	mm	N	N	Pcs	Kg	
3.2	9.0	6.4	0.80	1.0-3.0	1150	1300	1000	1.33	OSF-MG 3209
	12.0			3.0-5.0			1000	1.45	OSF-MG 3212
	14.0			5.0-7.0			1000	1.87	OSF-MG 3214
4.0	11.0	8.0	1.0	7.0-9.0	1800	2500	1000	1.75	OSF-MG 4011
	13.0			9.0-11.0			1000	1.92	OSF-MG 4013
4.8	10.0	9.5	1.20	11.0-13.0	2800	4000	1000	2.03	OSF-MG 4810
	11.0			2.0-4.0			1000	2.45	OSF-MG 4811
	14.0			4.0-6.0			1000	2.47	OSF-MG 4814
	17.0			6.0-8.0			1000	2.69	OSF-MG 4817

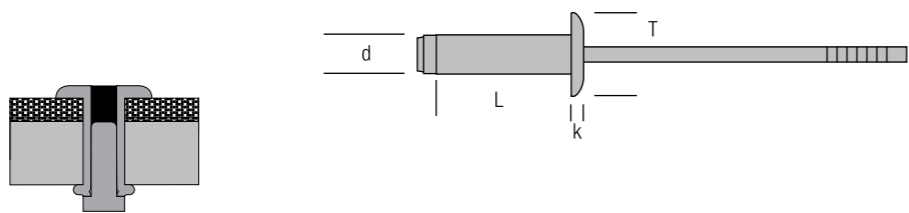

LOCKING TYPE BLIND RIVET									
d	L	T	K	mm		Pack Q'ty	Weight	Model No.	
mm	mm	mm	mm	mm	N	N	Pcs	Kg	
4.8	11.5	9.8	1.4	1.0-6.0	4415	3826	500	1.78	OSF-LCK 48115
	14.0			1.0-9.0			500	1.91	OSF-LCK 48140
6.4	10.5	8.0	1.0	1.0-5.0	1800	2500	250		OSF-LCK 64105
	12.5			1.0-5.0			250		OSF-LCK 64125
	14.5			1.0-9.5			250		OSF-LCK 64145
	16.5			3.0-12.5			250		OSF-LCK 64165
	20.5			3.0-16.0			250		OSF-LCK 64205

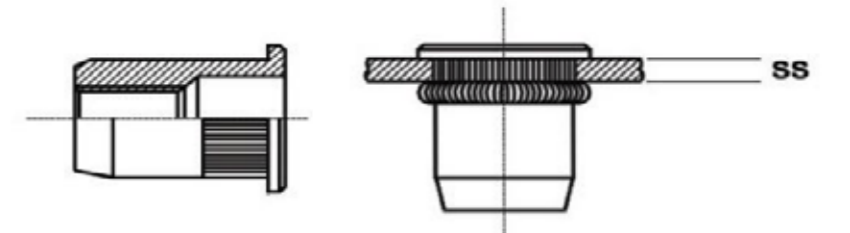

STEEL RIVET NUT - W/ FLANGE, CIRCULAR				
Size	SS	Hole Diameter	Pack Q'ty	Model No.
mm	mm	mm	Pcs	
3.0	0.5-2.0	5.0	500	OSF YFS3
4.0	0.5-2.5	6.0	500	OSF YFS4
5.0	0.5-3.0	7.0	500	OSF YFS5
6.0	0.5-3.0	9.0	250	OSF YFS6
8.0	0.5-3.5	11.0	250	OSF YFS8
10.0	1.0-3.5	13.0	250	OSF YFS10
12.0	1.0-4.0	16.0	250	OSF YFS12

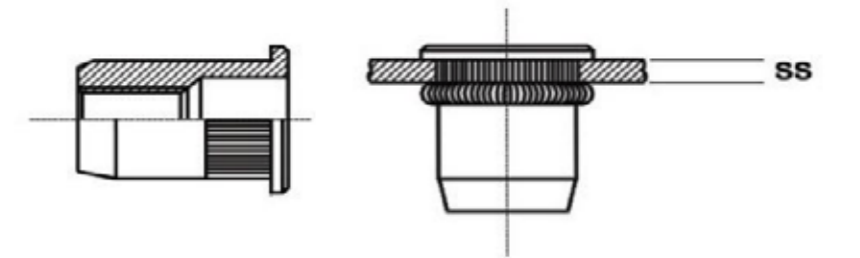

STEEL RIVET NUT - W/O FLANGE, CIRCULAR				
Size	SS	Hole Diameter	Pack Q'ty	Model No.
mm	mm	mm	Pcs	
3.0	0.5-2.0	5.0	500	OSF YSS3
4.0	0.5-2.5	6.0	500	OSF YSS4
5.0	0.5-3.0	7.0	500	OSF YSS5
6.0	0.5-3.0	9.0	250	OSF YSS6
8.0	0.5-3.5	11.0	250	OSF YSS8
10.0	1.0-3.5	13.0	250	OSF YSS10
12.0	1.0-4.0	16.0	250	OSF YSS12

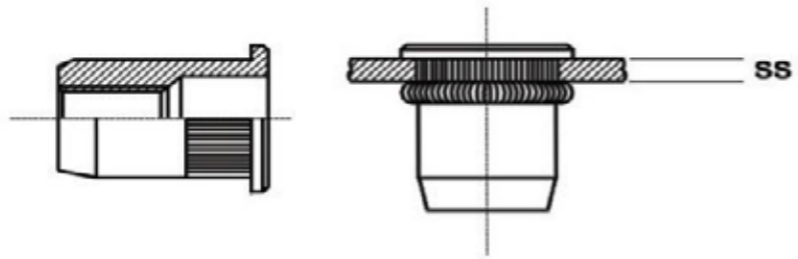

STEEL RIVET NUT - W/ FLANGE, HEXAGONAL

Size	SS	Hole Diameter	Pack Q'ty	Model No.
mm	mm	mm	Pcs	
3.0	0.5-2.0	5.0	500	OSFAFS3
4.0	0.5-2.5	6.0	500	OSFAFS4
5.0	0.5-3.0	7.0	500	OSFAFS5
6.0	0.5-3.0	9.0	250	OSFAFS6
8.0	0.5-3.5	11.0	250	OSFAFS8
10.0	1.0-3.5	13.0	250	OSFAFS10
12.0	1.0-4.0	16.0	250	OSFAFS12

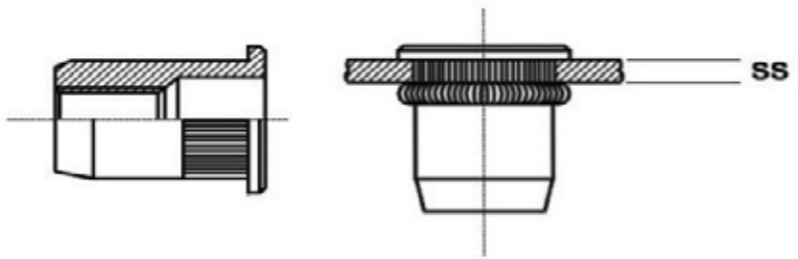

STEEL RIVET NUT - W/O FLANGE, HEXAGONAL

Size	SS	Hole Diameter	Pack Q'ty	Model No.
mm	mm	mm	Pcs	
3.0	0.5-2.0	5.0	500	OSFASS3
4.0	0.5-2.5	6.0	500	OSFASS4
5.0	0.5-3.0	7.0	500	OSFASS5
6.0	0.5-3.0	9.0	250	OSFASS6
8.0	0.5-3.5	11.0	250	OSFASS8
10.0	1.0-3.5	13.0	250	OSFASS10
12.0	1.0-4.0	16.0	250	OSFASS12

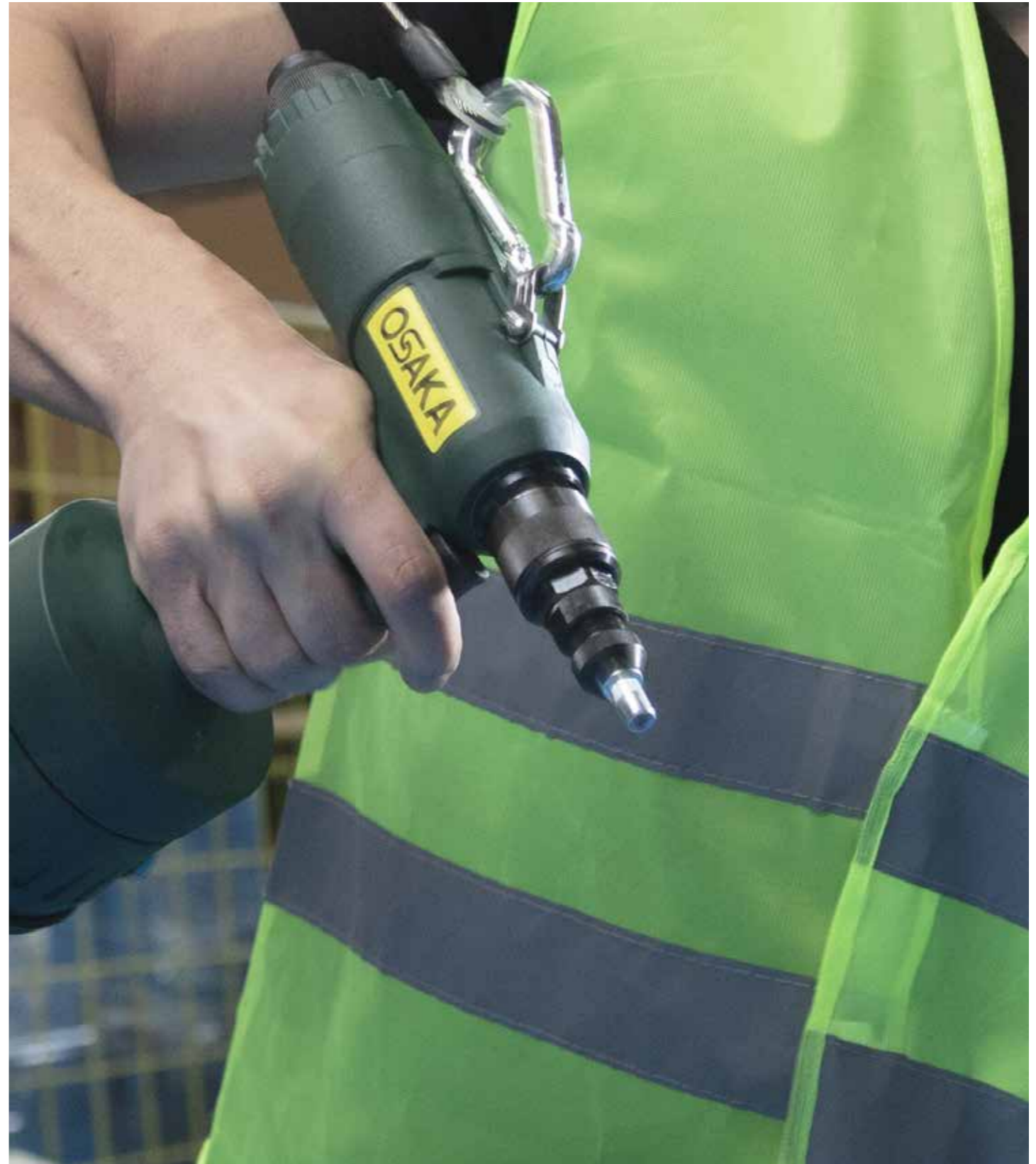



### SDS PLUS DRILL BITS

Diameter	Working Length	Whole Length
5	50	110
5	100	160
6	50	110
6	100	160
6	150	200
6	200	250
7	50	110
7	100	160
7	150	210
8	50	110
8	100	160
8	150	210
8	200	260
8	250	310
8	400	450
9	100	160
9	150	210
10	50	110
10	100	160
10	150	210
10	200	260
10	250	310
10	400	450
11	100	160
11	150	200
11	200	260
12	100	160
12	150	210
12	200	260
12	250	300
12	400	450
13	100	150
13	200	250
13	250	300
14	100	150
14	150	200
14	200	250
14	250	300
14	400	460
14	550	600
15	100	150
16	100	150
16	150	200
16	200	250
16	250	300
16	400	450
16	550	600
18	150	200
18	200	250
18	250	300
18	400	450
18	550	600
20	150	200
20	250	300
20	400	450
20	550	600
22	200	250
22	400	450
22	550	600
24	200	250
24	400	450
25	400	450
26	400	450



### SDS PLUS CHISELS

SDS PLUS	Chuck Adaptor
SDS PLUS	Point Chisel 250 mm
SDS PLUS	Flat Chisel 250 mm
SDS PLUS	Wide Flat Chisel



### SDS MAX DRILL BITS

Diameter	Working Length	Whole Length
12	200	340
12	400	540
14	200	340
14	400	540
16	200	340
16	400	540
18	200	340
18	400	540
20	200	320
20	400	520
22	200	320
22	400	520
22	800	920
24	200	320
24	400	520
25	200	320
25	400	520
25	800	920
26	200	340
26	400	520
28	250	370
28	450	570
30	250	370
30	450	570
32	250	370
32	450	570
32	800	920
35	250	370
35	450	570
38	250	370
38	450	570
40	250	370
40	800	920
45	450	570
50	450	570



### SDS MULTI CHANNEL DRILL BITS

Diameter	Working Length	Whole Length
12	200	330
14	250	380
16	250	380
16	400	530
18	250	380
20	250	380
20	400	530
22	200	330
22	400	530
24	200	330
24	400	530
25	200	330
25	400	530
28	250	380
28	400	530
28	550	630
30	400	530
32	250	380
32	400	530
35	400	530
38	400	530



### CERAMIC AND TILE DRILLING SET

449 €



DIAMOND GRANITE DRILL BITS	5 mm
DIAMOND GRANITE DRILL BITS	6 mm
DIAMOND GRANITE DRILL BITS	8 mm
DIAMOND GRANITE DRILL BITS	10 mm
CENTERING TOOL	
WATER CONNECTION VALVE	
WATER PUMP	



### SDS MAX CHISELS

	Length
SDS MAX POINT CHISEL	280
SDS MAX POINT CHISEL	400
SDS MAX POINT CHISEL	600
SDS MAX FLAT CHISEL	400
SDS MAX FLAT CHISEL	600
SDS MAX WIDE FLAT CHISEL	80x300
SDS MAX WIDE FLAT CHISEL	50x400

## METRIC BOLTS HEAD DIMENSIONS AND TIGHTENING TORQUES

Bolt Grade			3.6	4.6	4.8	5.6	5.8	6.8	8.8	10.9	12.9
			Torque (Nm)	Torque (Nm)	Torque (Nm)	Torque (Nm)	Torque (Nm)	Torque (Nm)	Torque (Nm)	Torque (Nm)	Torque (Nm)
M4	3	7	0.85	1,1	1,4	1,5	1,9	2,3	2,9	4,1	4,9
M5	4	9	1,7	2,2	2,8	3,0	3,7	4,5	6,0	8,5	10
M6	5	10	2,9	3,9	4,8	5,1	6,4	7,7	10	14	17
M8	6	13	7a	9,3	12	12	16	19	25	35	41
M10	8	17	14	19	23	25	31	37	49	69	83
M12	10	19	24	32	40	43	54	65	86	120	145
M14	12	22	39	51	64	68	86	105	135	190	230
M16	14	24	59	79	98	105	130	155	210	295	355
M18	14	27	81	110	135	145	180	215	290	405	485
M20	17	30	115	155	190	205	255	305	410	580	690
M22	17	32	155	205	260	275	345	415	550	780	930
M24	19	36	265	265	330	350	440	530	710	1000	1200
M27	19	41	295	390	490	520	650	780	1050	1500	1800
M30	22	46	395	530	660	710	880	1050	1450	2000	2400
M33	24	50	540	720	900	960	1200	1450	1900	2700	3250
M36	27	55	690	920	1150	1250	1550	1850	2450	3450	4150
M39	27	60	920	1200	1500	1600	2000	2400	3200	4500	5400
M42	32	65	1100	1500	1850	1950	2450	2950	3950	5500	6650
M45	32	70	1400	1850	2300	2450	3100	3700	4950	6950	8350
M48	36	75	1700	2250	2800	300	3750	4450	5950	8400	10100
M52	36	80	2150	2900	3600	3850	4800	5750	7650	10800	12900
M56	-	85	2700	3600	4500	4800	5950	7150	9550	13400	16100
M60	-	90	3350	4450	5500	5950	7400	8900	11900	16700	20000
M64	-	95	4000	5350	6700	7150	8950	10700	14300	20100	24100
M68	-	100	4850	6500	8100	8650	10800	13000	17300	24300	29100

### ROCKING DOG

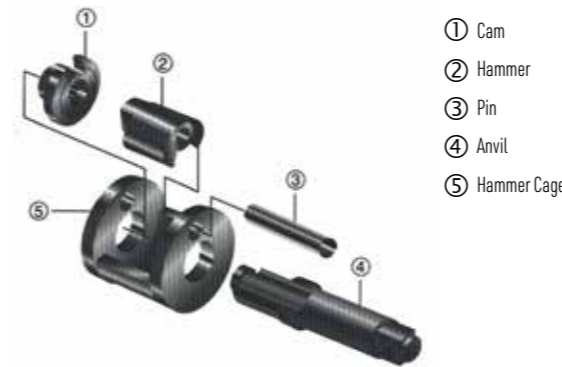

- ① Cam
- ② Hammer
- ③ Pin
- ④ Anvil
- ⑤ Hammer Cage

### PIN CLUTCH

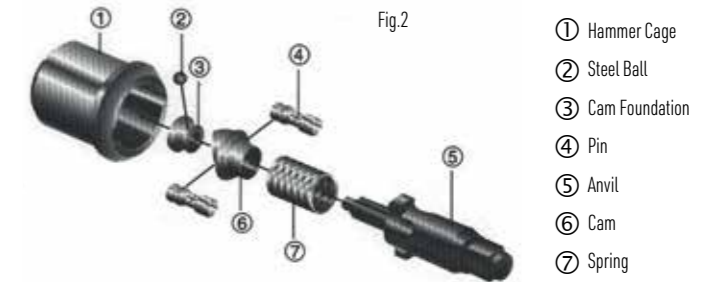

- ① Hammer Cage
- ② Steel Ball
- ③ Cam Foundation
- ④ Pin
- ⑤ Anvil
- ⑥ Cam
- ⑦ Spring

### TWIN HAMMER



- ① Hammer Cage
- ② Hammer
- ③ Pin
- ④ Anvil

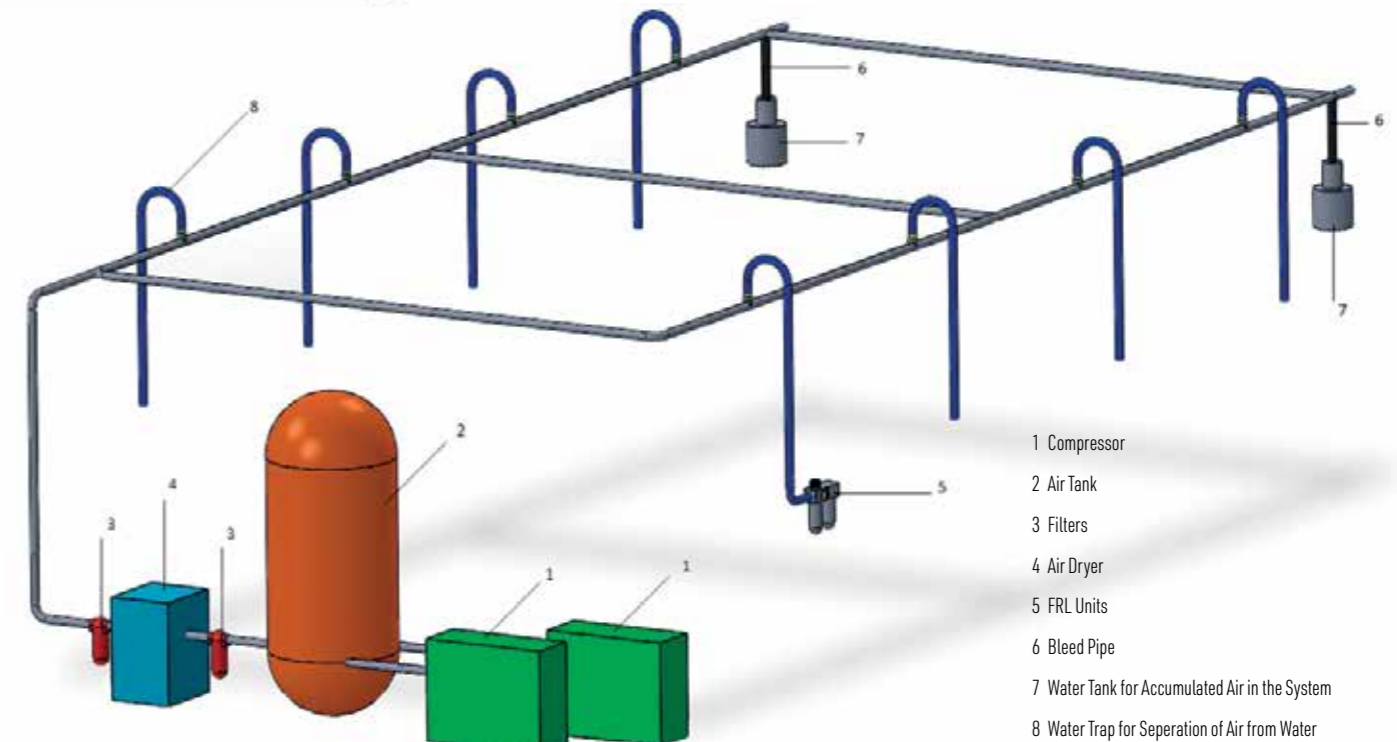

- 1 Compressor
- 2 Air Tank
- 3 Filters
- 4 Air Dryer
- 5 FRL Units
- 6 Bleed Pipe
- 7 Water Tank for Accumulated Air in the System
- 8 Water Trap for Separation of Air from Water

## SELECTION OF PIPELINES FOR PNEUMATIC SYSTEMS

In order to work efficiently in all work stations and for the importance of economic use of compressed air, reducing the drop in pressure in the farthest end of the pipeline is crucial. To achieve this, it is essential to use a loop type of piping should be use as shown in Fig.4, and straight type of piping should be avoided as much as possible. To keep the loss due to friction minimum, minimum number of bends should be used for the system.

Another factor which poses maintenance problems is the accumulated water in the pipeline. To get rid of it, it is essential for pipeline to have a slope of 6-10 mm per meter. This way, the accumulated water can be collected from the ends of the pipeline. To separate air gain to the tool from the water, use of water traps (shown in Fig.4) is essential.

Diferent type of pipes are used for the lines such as galvanized pipes, iron pipes, rubber pipes, pvc pipes etc. It is best to use galvanized pipes for the air mains, since they won't sag in time.

Nom. Diameter mm	Actual Diameter mm	Pipe Size Inch	Flow Rate l/min
6	6	1/4"	60
8	9	5/16"	180
10	12	3/8"	300
15	16	1/2"	600
20	22	3/4"	1,000
25	27	1"	1,500
32	36	1.1/4"	3,000
40	42	1.1/2"	3900
50	53	2"	6,000
65	69	2.1/2"	10800
80	81	3"	14,400
100	105	4"	24,600
125	130	5"	36600
150	155	6"	54,000

Table 1

Pressure bar	6 (1/4")	8 5/16"	10 3/8"	15 5/8"	20 3/4"	25 1"
4	102	220	500	920	1380	2640
6.3	150	340	760	1400	2100	3900
8	180	430	950	1750	2540	4980
10	240	539	1170	2170	3249	6000

Table 2

## PROPERTIES OF PIPING SYSTEM

Performance of airtools is proportional to the change in square of the pressures. That means for a pressure drop from 6 bar to 5 bar, the performance of the tool will decrease to 70%

$$\frac{5^2}{6^2} = \frac{25}{36} = 69.4\%$$

It is important to take the pressure loss through the main pipes due to flow friction into account. Following empirical formula give the drop in pressure.

$$\Delta P = \frac{(1.6 \times 10^3)(Q^{1.85}L)}{d^5 \times P_{abs}}$$

If we calculate the drop in pressure for compressor producing 7 bar with 265 l/s in 100 m pipe with an internal diameter of 80mm, the calculation yields

$$\Delta P = \frac{(1.6 \times 10^3)(0.265^{1.85} \times 100)}{0.08^5 \times 801325} = 5222.35 Pa \approx 0.0522 bar$$

$\Delta P$  = drop in pressure, Pa  
 $L$  = length of pipe, m  
 $Q$  = volumetric flow rate, m<sup>3</sup>/s  
 $d$  = internal diameter of the pipe, m  
 $P$  = absolute pressure of the air at the entrance of pipe, Pa

Pipe Diameter (mm)	Pressure Loss in 100 Meter Pipe (bar)	Equivalent Power Loss (kW)
40	1.80	9,5
50	0.65	3,4
65	0.22	1,2
80	0.04	0,2
100	0.02	0,1

Table 3

However most engineers rather use table when considering pressure drop in the pipelines. Table 3 shows the pressure loss in 100 m of pipe for various diameters and their equivalent power loss.

## PRODUCT INDEX

Sayfa No.	Model No.	Açıklama
53	OPC 00814	INDUSTRIAL PVC HOSE
53	OPC 01016	INDUSTRIAL PVC HOSE
53	OPC 01140	INDUSTRIAL PVC HOSE
53	OPC 01218	INDUSTRIAL PVC HOSE
53	OPC 01623	INDUSTRIAL PVC HOSE
53	OPC 01812	INDUSTRIAL PVC HOSE
52	OPT 05-25	SPIRAL HOSE
52	OPT 05-50	SPIRAL HOSE
52	OPT 06-25	SPIRAL HOSE
52	OPT 06-50	SPIRAL HOSE
53	OSA-H 0816	OXYGEN ACETYLENE HOSE
52	OPT 08-25	SPIRAL HOSE
52	OPT 08-50	SPIRAL HOSE
45	OPT-P 10	CHIPPING HAMMER
53	OSA-H 1020	OXYGEN ACETYLENE HOSE
45	OPT-P 11	CHIPPING HAMMER
52	OPT 11-25	SPIRAL HOSE
52	OPT 11-50	SPIRAL HOSE
52	OPT 11x16	PU HOSE ROLL
55	OPT MS-14	WATER HOSE REEL
44	OPT-P 12	CHIPPING HAMMER
44	OPT-P 15	CHIPPING HAMMER
31	OPT-P 100L	STRAIGHT GRINDER
54	OPT MH-100	AIR HOSE REEL
40	OPT-P 101	BLIND RIVET GUN
40	OPT 103K	BLIND RIVET GUN SET
40	OPT 103R	BLIND RIVET GUN
29	OPT-P 106-2	BLIND RIVET GUN SET
45	OPT-P 110	NEEDLE SCALER
16	OPT 113	DRILL 10MM
28	OPT-P 120	DIE GRINDER
28	OPT-P 120N	DIE GRINDER
28	OPT 121	DIE GRINDER
30	OPT-P 122S4	DIE GRINDER
30	OPT-P 122S5	DIE GRINDER
30	OPT-P 122S6	DIE GRINDER
30	OPT-P 122S8	EXTENDED STRAIGHT GRINDER
29	OPT 124	ANGLE DIE GRINDER
29	OPT 124N	ANGLE DIE GRINDER
33	OPT-P 125	GRINDER 50MM
29	OPT 126	PISTOL TYPE DIE GRINDER
28	OPT 127	DIE GRINDER
28	OPT-P 128	DIE GRINDER
15	OPT-P 130	DRILL 6.5MM
54	OPT MH-150	AIR HOSE REEL
44	OPT 150-6K	CHIPPING HAMMER
55	OPT MK-165	AUTO CABLE REEL
44	OPT-P 180-4K	CHIPPING HAMMER
44	OPT-P 180-5K	CHIPPING HAMMER
44	OPT 190-4K	CHIPPING HAMMER

Sayfa No.	Model No.	Açıklama
49	OPT-P 1000	WATER FILTER
26	OPT 1005	SIDE CUTTER
26	OPT 1006	SIDE CUTTER
26	OPT 1007	SIDE CUTTER
26	OPT 1008	SIDE CUTTER
31	OPT-P 1503	MICRO DIE GRINDER
32	OPT-P 1504	MICRO DIE GRINDER
32	OPT-P 1505	MICRO DIE GRINDER
52	OPT 2.5x4	PU HOSE ROLL
55	OPT MS-20	WATER HOSE REEL
45	OPT-P 20	CHIPPING HAMMER
26	OPT-P 200	STEEL STRAPPING TOOL
54	OPT MH-200	AIR HOSE REEL
46	OPT 201	VACUUM
47	OPT 203	CAULKING GUN
47	OPT 206	GREASE GUN
16	OPT 208	DRILL 6.5MM
54	OPT MH-210	AIR HOSE REEL
27	OPT 216	GLASS RUN CHANNEL CUTTER
54	OPT MH-220	AIR HOSE REEL
46	OPT-P 220	MIXER
46	OPT-P 221	MIXER BARREL TYPE
54	OPT MH-230	AIR HOSE REEL
15	OPT 230	DRILL 10MM
15	OPT 232	DRILL 10MM
15	OPT 232A	DRILL 10MM
16	OPT 237	DRILL 13MM
16	OPT 237-8	DRILL 13MM
16	OPT 239	DRILL 16MM
4	OPT-P 243	3/8" IMPACT WRENCH
55	OPT MK-250	AUTO CABLE REEL
55	OPT MS-28	WATER HOSE REEL
45	OPT 281	NEEDLE SCALER
49	OPT-P 2000	WATER FILTER
48	OPT 2012 FR	WATER FILTER
14	OSA-TW 2030	DIGITAL TORQUE ARM
47	OPT 2032-13	CAULKING GUN
47	OPT-P 2034-13	CAULKING GUN
48	OPT 2042 FR	WATER FILTER
53	OSA-H 2816	DOUBLE HOSE
15	OPC 20201C	DRILL 10MM
15	OPC 20202	DRILL 10MM
21	OPC 21808	TAPPING MACHINE
21	OPC 21812	TAPPING MACHINE
52	OPT 3x5	PU HOSE ROLL
22	OPT-P 3-12K	TAPPING MACHINE
22	OPT-P 3-16K	TAPPING MACHINE
23	OPT-P 3-16K90	TAPPING MACHINE 90°
20	OPT 304	SCREWDRIVER
20	OPT 304-B	PUSH START SCREWDRIVER

## PRODUCT INDEX

Sayfa No.	Model No.	Açıklama
36	OPT-P 309B	ORBIT SANDER W/ VACUUM
36	OPT-P 309BW	ORBIT SANDER
27	OPT 310	SHEET METAL CUTTER
39	OPT-P 312C	SAW
39	OPT 313	SAW
27	OPT 315	FILING MACHINE
27	OPT 315 LV	FILING MACHINE
10	OPT-P 317	IMPACT WRENCH 1"
10	OPT-P 317L	IMPACT WRENCH 1"
10	OPT-P 318	IMPACT WRENCH 1"
10	OPT-P 318L	IMPACT WRENCH 1"
39	OPT-P 319	SAW
27	OPT 330	SHEET METAL CUTTER
14	OPT 360K	RATCHET WRENCH SET 3/8"
38	OPT-P 363	PALM SANDER
13	OPT 367	RATCHET WRENCH 1/4"
38	OPT-P 368	MINI ANGLE SANDER
4	OPT 371	IMPACT WRENCH 3/8"
4	OPT 375	IMPACT WRENCH 3/8"
13	OPT 378	3/8" RATCHET WRENCH
13	OPT-P 389	RATCHET WRENCH 1/2"
14	OPT-P 398	ANGLE IMPACT WRENCH 1/2"
49	OPT-P 3000	WATER FILTER
48	OPT 3012 FR-L	FRL UNIT
48	OPT 3042 FR-L	FRL UNIT
14	OSA-TW 3135	DIGITAL TORQUE ARM
29	OPT 4	DIE GRINDER SET
52	OPT 4x6	PU HOSE ROLL
22	OPT-P 4-22K	TAPPING MACHINE
23	OPT-P 4-22K90	TAPPING MACHINE 90°
20	OPT 402	IMPACT SCREWDRIVER
10	OPT-P 418	IMPACT WRENCH 1"
10	OPT-P 418L	IMPACT WRENCH 1"
13	OPT-P 450A	RATCHET WRENCH 1/2"
14	OPT-P 450C	ANGLE IMPACT WRENCH 1/2"
40	OPT-P 4000R	BLIND RIVET GUN
48	OPT 4042 FR-L	FRL UNIT
17	OPT 4080-6	SCREWDRIVER
17	OPT 4080-8	SCREWDRIVER
20	OPT 4080-D	DIRECT DRIVE SCREWDRIVER
17	OPT-P 4250	IMPACT SCREWDRIVER
14	OSA-TW 4340	DIGITAL TORQUE ARM
17	OPC 40206C	SCREWDRIVER
17	OPC 40208C	SCREWDRIVER
18	OPC 44204	TORQUE ADJUSTABLE SCREWDRIVER
18	OPC 44205	TORQUE ADJUSTABLE SCREWDRIVER
18	OPC 44206	TORQUE ADJUSTABLE SCREWDRIVER
19	OPC 44208	TORQUE ADJUSTABLE SCREWDRIVER
19	OPC 44209	TORQUE ADJUSTABLE SCREWDRIVER
17	OPC 48116	IMPACT SCREWDRIVER

Sayfa No.	Model No.	Açıklama
52	OPT 5x8	PU HOSE ROLL
38	OPT 500A	PALM SANDER
31	OPT-P 501	MICRO DIE GRINDER
5	OPT-P 504C	STUBBY IMPACT WRENCH 1/2"
33	OPT 505	GRINDER PISTOL TYPE
7	OPT-P 508E	IMPACT WRENCH 3/4"
34	OPT-P 509	GRINDER 180MM
31	OPT-P 513	ANGLE MICRO DIE GRINDER
29	OPT-P 515	DIE GRINDER
5	OPT 517	IMPACT WRENCH 1/2"
5	OPT 517K	IMPACT WRENCH SET 1/2"
5	OPT-P 519	IMPACT WRENCH 1/2"
5	OPT-P 520	IMPACT WRENCH 1/2"
11	OPT-P 560	IMPACT WRENCH 1"
11	OPT-P 560-12	IMPACT WRENCH 1.5"
11	OPT-P 560-12GX	IMPACT WRENCH 1.5"
11	OPT-P 560-12GXL	IMPACT WRENCH 1.5"
11	OPT-P 560-12L	IMPACT WRENCH 1.5"
11	OPT-P 560L	IMPACT WRENCH 1"
23	OSI 570	REACTION ARM
41	OPT-P 5012	BLIND RIVET GUN
41	OPT-P 5020	BLIND RIVET GUN
41	OPT-P 5040N	BLIND RIVET GUN
42	OPT-P 5050	RIVET NUT TOOL
42	OPT-P 5050AS	RIVET NUT TOOL
41	OPT-P 5060I	BLIND RIVET GUN
41	OPT-P 5075	LOCKBOLT BLIND RIVET TOOL
42	OPT-P 5170R	BATTERY BLIND RIVET TOOL
42	OPT-P 50100	RIVET NUT TOOL
4	OPC 50138	3/8" IMPACT WRENCH
4	OPC 50238C	3/8" IMPACT WRENCH
5	OPC 51112 MCN	IMPACT WRENCH 1/2"
8	OPC 51134	3/4" IMPACT WRENCH
6	OPC 51212 MCN	IMPACT WRENCH 1/2"
6	OPC 51212 MCNL	IMPACT WRENCH 1/2"
7	OPC 51212C	COMPOSITE IMPACT WRENCH 1/2"
7	OPC 51212CL	COMPOSITE IMPACT WRENCH 1/2"
6	OPC 51234 MCN	3/4" IMPACT WRENCH
6	OPC 51234 MCNL	3/4" IMPACT WRENCH
7	OPC 51234C	COMPOSITE IMPACT WRENCH 3/4"
7	OPC 51234CL	COMPOSITE IMPACT WRENCH 3/4"
6	OPC 51310 MCN	1" IMPACT WRENCH
6	OPC 51310 MCNL	1" IMPACT WRENCH
13	OPC 55214	RATCHET WRENCH 1/2"
4	OPT-P 59212	BATTERY IMPACT WRENCH 3/8"
40	OPT-PS 6	RIVET NUT TOOL
52	OPT 6.5x10	PU HOSE ROLL
8	OPT 600	3/4" IMPACT WRENCH
8	OPT 600K	IMPACT WRENCH SET 3/4"
39	OPT-P 618	SPOT DRILL

## PRODUCT INDEX

Sayfa No.	Model No.	Açıklama
7	OPT-P 625	3/4" IMPACT WRENCH
13	OPT 650B	RATCHET WRENCH 1/2"
39	OPT 673	PALM HAMMER
27	OPT-P 690	NIBBLER
33	OPT-P 6115	GRINDER 125MM
34	OPT-P 6180	GRINDER 180MM
34	OPC 6218	GRINDER 180MM
33	OPT-P 6315	GRINDER 125MM
33	OPC 60215	GRINDER 125MM
34	OPC 60218	GRINDER 180MM
33	OPC 60225C	GRINDER 75MM
34	OPC 60230	GRINDER 230MM
28	OPC 61119	DIE GRINDER
30	OPC 62050	DIE GRINDER
30	OPC 62075	DIE GRINDER
36	OPC 62223D	ORBIT SANDER
36	OPC 62303B	ORBIT SANDER
36	OPC 62403	ORBIT SANDER W/ VACUUM
37	OPC 65110C	FIBER SANDER
31	OPC 68150	STRAIGHT GRINDER
36	OPT 700A	ORBIT SANDER
37	OPT-P 701	BELT SANDER
37	OPT-P 701C	COMPOSITE BELT SANDER
37	OPT-P 702	BELT SANDER
37	OPT-P 702C	COMPOSITE BELT SANDER
38	OPT 706	PALM SANDER
37	OPT 708	AIR GRATER
16	OPT 709-R	ANGLE DRILL 10MM
46	OPT-P 710LK	NEEDLE SCALER
38	OPT-P 716A	MINI ANGLE SANDER
18	OPT-P 726	TORQUE ADJUSTABLE SCREWDRIVER
18	OPT-P 766	TORQUE ADJUSTABLE SCREWDRIVER
18	OPT-P 768	TORQUE ADJUSTABLE SCREWDRIVER
23	OSI 790	REACTION ARM
35	OPT-P 791	POLISHER
35	OPT-P 793	POLISHER
32	OPT-P 7203	FILING MACHINE
32	OPT-P 7205	FILING MACHINE
32	OPT-P 7212	FILING MACHINE
32	OPT-P 7301	FILING MACHINE
52	OPT 8x12	PU HOSE ROLL
38	OPT-P 800A	ORBIT SANDER
20	OPT 842	SCREWDRIVER
20	OPT 843	SCREWDRIVER
25	OPT 8016	STAPLER GUN
26	OPT-P 85135	MECHANIC CARTON STAPLER
25	OPT-P 85235	PNEUMATIC CARTON STAPLER
25	OPT-P 85335	PNEUMATIC CARTON STAPLER
25	OPT-P 85435	PNEUMATIC CARTON STAPLER
25	OPT-P 85735J	JUMBO CARTON STAPLER

Sayfa No.	Model No.	Açıklama
24	OPT 86032	NAILER 32MM
24	OPT 86050	NAILER 50MM
24	OPT 86055	NAILER 55MM
24	OPT 86064	NAILER 64MM
24	OPT 86070	NAILER 70MM
24	OPT 86090	NAILER 90MM
25	OPT 86130	NAILER 130MM
46	OPT 923	SCALING HAMMER
31	OPT-P 940	ENGRAVING PEN
23	OPT-P HM32-K	HYDRAULIC TAPPING MACHINE
21	OPT-P KC 12-3	TAPPING MACHINE
21	OPT-P KC 16-3	TAPPING MACHINE
21	OPT-P KC 22-4	TAPPING MACHINE
46	OPT-P QS-2	AIR DENT PULLER

# Export Destinations

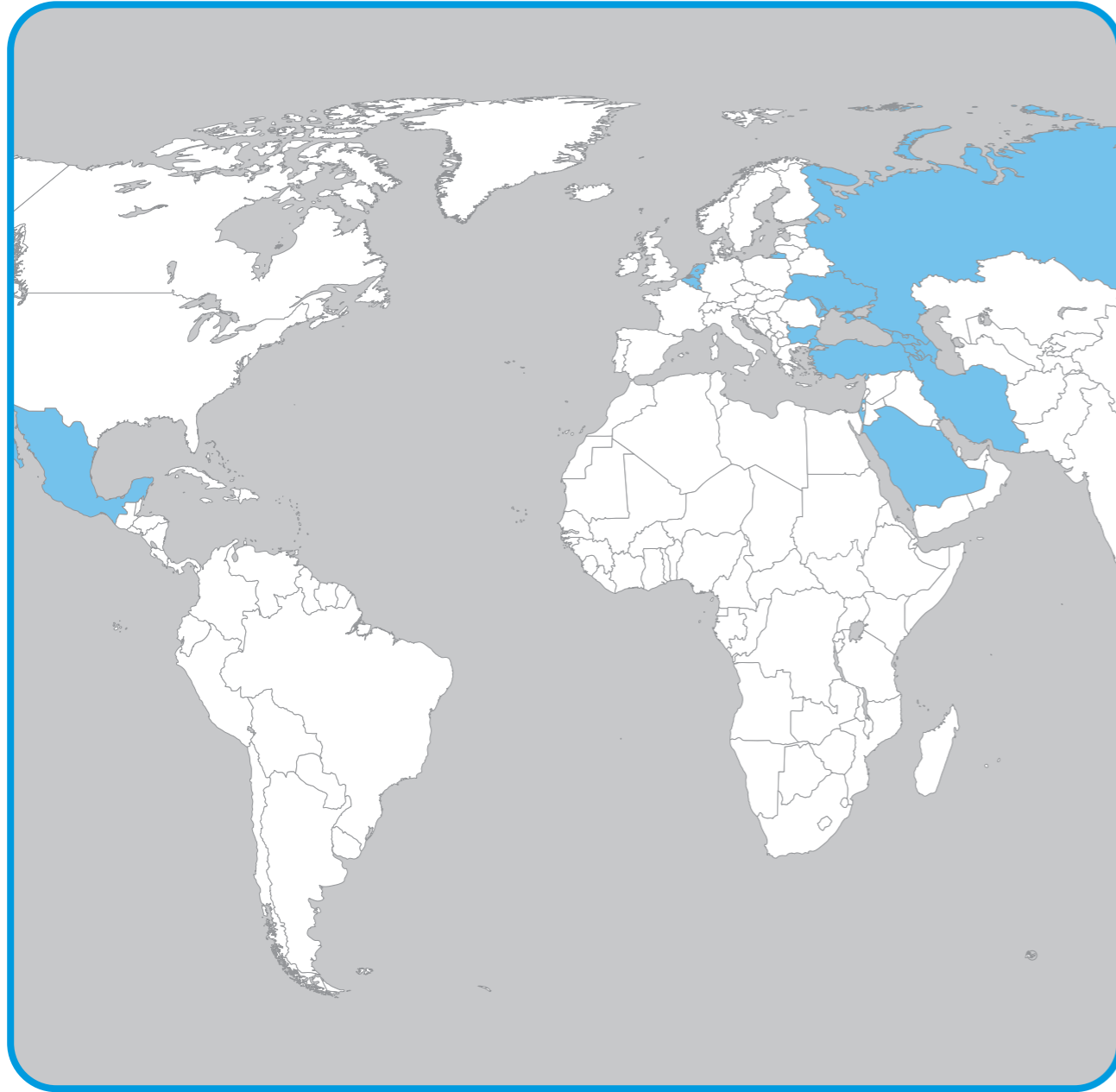

OSAKA - Armenia	OSAKA - Azerbaijan	OSAKA - Bulgaria	OSAKA - Georgia
OSAKA - Iran	OSAKA - Israel	OSAKA - Mexico	OSAKA - Moldova
OSAKA - Netherland	OSAKA - Russia	OSAKA - Saudi Arabia	OSAKA - Turkey
OSAKA - Ukrain			

